

# DAQ

---

## PCI/PXI™ -6602 User Manual

High-Speed Counter/Timer  
for PCI or PXI Bus Systems

**Internet Support**

E-mail: [support@natinst.com](mailto:support@natinst.com)

FTP Site: <ftp.natinst.com>

Web Address: <http://www.natinst.com>

**Bulletin Board Support**

BBS United States: 512 794 5422

BBS United Kingdom: 01635 551422

BBS France: 01 48 65 15 59

**Fax-on-Demand Support**

512 418 1111

**Telephone Support (USA)**

Tel: 512 795 8248

Fax: 512 794 5678

**International Offices**

Australia 03 9879 5166, Austria 0662 45 79 90 0, Belgium 02 757 00 20, Brazil 011 288 3336,  
Canada (Ontario) 905 785 0085, Canada (Québec) 514 694 8521, Denmark 45 76 26 00, Finland 09 725 725 11,  
France 01 48 14 24 24, Germany 089 741 31 30, Hong Kong 2645 3186, Israel 03 6120092, Italy 02 413091,  
Japan 03 5472 2970, Korea 02 596 7456, Mexico 5 520 2635, Netherlands 0348 433466, Norway 32 84 84 00,  
Singapore 2265886, Spain 91 640 0085, Sweden 08 730 49 70, Switzerland 056 200 51 51, Taiwan 02 377 1200,  
United Kingdom 01635 523545

**National Instruments Corporate Headquarters**

6504 Bridge Point Parkway Austin, Texas 78730-5039 USA Tel: 512 794 0100

# Important Information

---

## Warranty

The PCI-6602 and PXI-6602 are warranted against defects in materials and workmanship for a period of one year from the date of shipment, as evidenced by receipts or other documentation. National Instruments will, at its option, repair or replace equipment that proves to be defective during the warranty period. This warranty includes parts and labor.

The media on which you receive National Instruments software are warranted not to fail to execute programming instructions, due to defects in materials and workmanship, for a period of 90 days from date of shipment, as evidenced by receipts or other documentation. National Instruments will, at its option, repair or replace software media that do not execute programming instructions if National Instruments receives notice of such defects during the warranty period. National Instruments does not warrant that the operation of the software shall be uninterrupted or error free.

A Return Material Authorization (RMA) number must be obtained from the factory and clearly marked on the outside of the package before any equipment will be accepted for warranty work. National Instruments will pay the shipping costs of returning to the owner parts which are covered by warranty.

National Instruments believes that the information in this manual is accurate. The document has been carefully reviewed for technical accuracy. In the event that technical or typographical errors exist, National Instruments reserves the right to make changes to subsequent editions of this document without prior notice to holders of this edition. The reader should consult National Instruments if errors are suspected. In no event shall National Instruments be liable for any damages arising out of or related to this document or the information contained in it.

EXCEPT AS SPECIFIED HEREIN, NATIONAL INSTRUMENTS MAKES NO WARRANTIES, EXPRESS OR IMPLIED, AND SPECIFICALLY DISCLAIMS ANY WARRANTY OF MERCHANTABILITY OR FITNESS FOR A PARTICULAR PURPOSE. CUSTOMER'S RIGHT TO RECOVER DAMAGES CAUSED BY FAULT OR NEGLIGENCE ON THE PART OF NATIONAL INSTRUMENTS SHALL BE LIMITED TO THE AMOUNT THEREFORE PAID BY THE CUSTOMER. NATIONAL INSTRUMENTS WILL NOT BE LIABLE FOR DAMAGES RESULTING FROM LOSS OF DATA, PROFITS, USE OF PRODUCTS, OR INCIDENTAL OR CONSEQUENTIAL DAMAGES, EVEN IF ADVISED OF THE POSSIBILITY THEREOF. This limitation of the liability of National Instruments will apply regardless of the form of action, whether in contract or tort, including negligence. Any action against National Instruments must be brought within one year after the cause of action accrues. National Instruments shall not be liable for any delay in performance due to causes beyond its reasonable control. The warranty provided herein does not cover damages, defects, malfunctions, or service failures caused by owner's failure to follow the National Instruments installation, operation, or maintenance instructions; owner's modification of the product; owner's abuse, misuse, or negligent acts; and power failure or surges, fire, flood, accident, actions of third parties, or other events outside reasonable control.

## Copyright

Under the copyright laws, this publication may not be reproduced or transmitted in any form, electronic or mechanical, including photocopying, recording, storing in an information retrieval system, or translating, in whole or in part, without the prior written consent of National Instruments Corporation.

## Trademarks

ComponentWorks™, CVI™, DAQCard™, DAQPad™, LabVIEW™, MITE™, natinst.com™, NI-DAQ™, PXI™, RTSI™, SCXI™, and VirtualBench™ are trademarks of National Instruments Corporation.

Product and company names listed are trademarks or trade names of their respective companies.

## WARNING REGARDING MEDICAL AND CLINICAL USE OF NATIONAL INSTRUMENTS PRODUCTS

National Instruments products are not designed with components and testing intended to ensure a level of reliability suitable for use in treatment and diagnosis of humans. Applications of National Instruments products involving medical or clinical treatment can create a potential for accidental injury caused by product failure, or by errors on the part of the user or application designer. Any use or application of National Instruments products for or involving medical or clinical treatment must be performed by properly trained and qualified medical personnel, and all traditional medical safeguards, equipment, and procedures that are appropriate in the particular situation to prevent serious injury or death should always continue to be used when National Instruments products are being used. National Instruments products are NOT intended to be a substitute for any form of established process, procedure, or equipment used to monitor or safeguard human health and safety in medical or clinical treatment.

# Contents

---

## About This Manual

Organization of This Manual .....	xi
Conventions Used in This Manual .....	xii
National Instruments Documentation .....	xii
Related Documentation.....	xiii
Customer Communication .....	xiii

## Chapter 1

### Introduction

About the 6602 Devices.....	1-1
Using PXI with CompactPCI.....	1-1
What You Need to Get Started .....	1-2
Unpacking .....	1-3
Software Programming Choices .....	1-3
National Instruments Application Software .....	1-4
NI-DAQ Driver Software .....	1-4
Optional Equipment .....	1-6

## Chapter 2

### Installation and Configuration

Software Installation .....	2-1
Hardware Installation.....	2-1
PCI and PXI Device Configuration .....	2-3

## Chapter 3

### Device Overview

Device Description .....	3-1
Functionality .....	3-2
Counter Applications.....	3-2
Simple Counting and Time Measurement .....	3-3
Event Counting .....	3-3
Simple Event Counting .....	3-4
Gated-Event Counting .....	3-4
Time Measurement .....	3-5
Single-Period Measurement .....	3-5
Single Pulse-Width Measurement .....	3-5
Two-Signal Edge-Separation Measurement .....	3-6

Simple Pulse and Pulse-Train Generation .....	3-7
Simple Pulse Generation .....	3-7
Single Pulse Generation .....	3-7
Single-Triggered Pulse Generation .....	3-8
Retriggerable Single Pulse Generation .....	3-8
Pulse-Train Generation .....	3-9
Continuous Pulse-Train Generation .....	3-9
Frequency Shift Keying (FSK) .....	3-10
Buffered Counting and Time Measurements .....	3-10
Buffered Event Counting .....	3-11
Buffered Period Measurement .....	3-11
Buffered Semiperiod Measurement .....	3-12
Buffered Pulse-Width Measurement .....	3-13
Buffered Two-Signal Edge-Separation Measurement .....	3-13
Other Counter Applications .....	3-14
Pulse Generation for ETS .....	3-14
Buffered Periodic Event Counting .....	3-15
Frequency Measurement .....	3-16
Buffered Frequency Measurement .....	3-16
Finite Pulse-Train Generation .....	3-17
Frequency Division .....	3-17
Reciprocal Frequency Measurement .....	3-17
Position Measurement .....	3-18
Quadrature Encoders .....	3-18
Two-Pulse Encoders .....	3-20
Miscellaneous Functions .....	3-20
Filters .....	3-20
Flexible Period and Frequency Measurements .....	3-22
Digital I/O .....	3-25
Prescaling .....	3-26
Simultaneous Arming of Counters .....	3-26
Pad Synchronization .....	3-26
Synchronous Counting Mode .....	3-28
When Synchronous Counting Mode Should Be Used .....	3-29
When Synchronous Counting Should Not Be Used .....	3-30
Transfer Rates .....	3-30

## Chapter 4

### Signal Connections

I/O Connector .....	4-1
Output on Counter Pins .....	4-6
Counter Input Selections .....	4-8

Signal Characteristics .....	4-12
RTSI Bus Interface .....	4-13
Board and RTSI Clocks .....	4-13
RTSI Triggers .....	4-13
Pull-Up and Pull-Down Connections .....	4-14
Power Connections .....	4-14
Field Wiring and Termination .....	4-15
Transmission Line Effects .....	4-15
Noise .....	4-16
Crosstalk .....	4-16
Inductive Effects .....	4-17

## **Appendix A Specifications**

## **Appendix B Timing Specifications**

## **Appendix C Block Diagram**

## **Appendix D Customer Communication**

## **Glossary**

## **Index**

## **Figures**

Figure 1-1. The Relationship between the Programming Environment, NI-DAQ, and Your Hardware .....	1-5
Figure 3-1. Simple Event Counting .....	3-4
Figure 3-2. Gated-Event Counting .....	3-4
Figure 3-3. Single-Period Measurement .....	3-5
Figure 3-4. Single Pulse-Width Measurement .....	3-6
Figure 3-5. Two-Signal Edge-Separation Measurement .....	3-6
Figure 3-6. Output Modes .....	3-7
Figure 3-7. Single Pulse Generation .....	3-8

Figure 3-8.	Single-Triggered Pulse Generation.....	3-8
Figure 3-9.	Retriggerable Single Pulse Generation .....	3-9
Figure 3-10.	Continuous Pulse-Train Generation.....	3-10
Figure 3-11.	Frequency Shift Keying .....	3-10
Figure 3-12.	Buffered Event Counting .....	3-11
Figure 3-13.	Buffered Period Measurement .....	3-12
Figure 3-14.	Buffered Semiperiod Measurement .....	3-12
Figure 3-15.	Buffered Pulse-Width Measurement.....	3-13
Figure 3-16.	Buffered Two-Signal Edge-Separation Measurement .....	3-14
Figure 3-17.	Pulse Generation for ETS .....	3-15
Figure 3-18.	Buffered Periodic Event Counting.....	3-15
Figure 3-19.	Frequency Measurement.....	3-16
Figure 3-20.	Buffered Frequency Measurement.....	3-16
Figure 3-21.	Finite Pulse-Train Generation.....	3-17
Figure 3-22.	Frequency Division.....	3-17
Figure 3-23.	Reciprocal Frequency Measurement.....	3-18
Figure 3-24.	Position Measurement for X1 Encoders .....	3-18
Figure 3-25.	Position Measurement for X2 Encoders .....	3-19
Figure 3-26.	Position Measurement for X4 Encoders .....	3-19
Figure 3-27.	Channel Z Reload .....	3-20
Figure 3-28.	Two-Pulse Encoders .....	3-20
Figure 3-29.	Filters .....	3-21
Figure 3-30.	Counter1 Used for Frequency and Period Measurements .....	3-24
Figure 3-31.	Counters 0 and 1 Used for Frequency and Period Measurements Simultaneously.....	3-25
Figure 3-32.	Prescaling .....	3-26
Figure 3-33.	Counters 0 and 1 Using PFI_38 as Gate without Pad Synchronization .....	3-27
Figure 3-34.	Counters 0 and 1 Using PFI_38 as Gate with Pad Synchronization .....	3-28
Figure 3-35.	Without Synchronous Counting Mode .....	3-29
Figure 3-36.	With Synchronous Counting Mode .....	3-29
Figure 4-1.	Comprehensive Description of PFI Line Functionality .....	4-2
Figure 4-2.	Description of PFI Lines for Counter Applications .....	4-3
Figure 4-3.	Description of PFI Lines for DIO Applications.....	4-4
Figure 4-4.	Description of PFI Lines for Motion Encoder Applications.....	4-5
Figure 4-5.	Counter Input .....	4-8
Figure 4-6.	Parallel and Series Termination .....	4-16
Figure 4-7.	Crosstalk .....	4-17
Figure 4-8.	Wiring to Minimize Inductive Effects .....	4-18
Figure B-1.	Counter SOURCE Minimum Period and Minimum Pulse Width .....	B-1
Figure B-2.	Counter GATE Minimum Pulse Width .....	B-2

Figure B-3. Counter Source to Counter Out Timing .....B-3

Figure C-1. PCI/PXI-6602 Block Diagram .....C-1

## Tables

Table 1-1. Pins Used by the PXI-6602 Device ..... 1-2

Table 3-1. Counter-Based Applications .....3-2

Table 3-2. Properties of the Different Filter Settings .....3-22

Table 3-3. Period Measurements ..... 3-23

Table 4-1. Signals That Can Be Driven onto the PFI Lines .....4-6

Table 4-2. Possible Selections for Counter Input .....4-9

Table 4-3. Signals That Can Be Driven onto the RTSI Bus .....4-14

Table 4-4. Pin Number of Associated GND on 68-Pin Connector Block .....4-18

Table B-1. Counter SOURCE Minimum Period and Minimum Pulse Width .....B-1

Table B-2. Counter GATE Minimum Pulse Width.....B-2

Table B-3. Counter Source to Counter Out Timing .....B-3



# About This Manual

---

This manual describes the electrical and mechanical aspects of 6602 devices, and contains information concerning their operation and programming. Unless otherwise noted, text applies to both 6602 devices, the PCI-6602 and PXI-6602. The PCI and PXI implementations are the same in functionality; their primary difference is the bus interface.

## Organization of This Manual

---

The *PCI/PXI-6602 User Manual* is organized as follows:

- Chapter 1, *Introduction*, describes the 6602 devices, lists what you need to get started, describes optional equipment, and explains how to unpack your device.
- Chapter 2, *Installation and Configuration*, explains how to install and configure your 6602 device.
- Chapter 3, *Device Overview*, provides an overview of the hardware functions of your 6602 device.
- Chapter 4, *Signal Connections*, describes how to make input and output signal connections to your 6602 device via the device I/O connector and RTSI connector.
- Appendix A, *Specifications*, lists specifications for the 6602 devices.
- Appendix B, *Timing Specifications*, provides timing specifications for the counters on your 6602 device.
- Appendix C, *Block Diagram*, shows the block diagram for the 6602 devices.
- Appendix D, *Customer Communication*, contains forms you can use to request help from National Instruments or to comment on our products.
- The *Glossary* contains an alphabetical list and descriptions of terms used in this manual, including acronyms, abbreviations, definitions, metric prefixes, mnemonics, and symbols.
- The *Index* alphabetically lists topics covered in this manual, including the page where you can find the topic.

## Conventions Used in This Manual

---

The following conventions are used in this manual:

<>	Angle brackets containing numbers separated by an ellipsis represent a range of values associated with a bit or signal name (for example, DIO<0..7>).
◆	The ◆ symbol indicates that the text following it applies only to a specific 6602 device.
<b>bold</b>	Bold text denotes the names of menus, menu items, parameters, dialog boxes, dialog box buttons or options, icons, windows, Windows 95 tabs, or LEDs.
<i>bold italic</i>	Bold italic text denotes a note, caution, or warning.
6602 device	Refers to the PCI-6602 and PXI-6602, unless otherwise noted.
<i>italic</i>	Italic text denotes emphasis, a cross reference, or an introduction to a key concept.  The <i>Glossary</i> lists abbreviations, acronyms, definitions, metric prefixes, mnemonics, symbols, and terms.

## National Instruments Documentation

---

The *PCI/PXI-6602 User Manual* is one piece of the documentation set for your data acquisition (DAQ) system. You could have any of several types of documentation, depending on the hardware and software in your system. Use the different types of documentation you have as follows:

- Your DAQ hardware user manuals—These manuals have detailed information about the DAQ hardware that plugs into or is connected to your computer. Use these manuals for hardware installation and configuration instructions, specification information about your DAQ hardware, and application hints.
- Software documentation—Examples of software documentation you may have are the LabVIEW, LabWindows/CVI, and NI-DAQ documentation. After you set up your hardware system, use either the application software or the NI-DAQ documentation to help you write your application. If you have a large, complicated system, it is worthwhile to look through the software documentation before you configure your hardware.

- Accessory installation guides or manuals—If you are using accessory products, read the terminal block and cable assembly installation guides or accessory board user manuals. They explain how to physically connect the relevant pieces of the system. Consult these guides when you are making your connections.

## Related Documentation

---

The following documents contain information that you may find helpful as you read this manual:

- Your computer's technical reference manual
- National Instruments *PXI Specification*, rev. 1.0
- PICMG CompactPCI 2.0 R2.1

## Customer Communication

---

National Instruments wants to receive your comments on our products and manuals. We are interested in the applications you develop with our products, and we want to help if you have problems with them. To make it easy for you to contact us, this manual contains comment and configuration forms for you to complete. These forms are in Appendix D, *Customer Communication*, at the end of this manual.

---

# Introduction

This chapter describes the 6602 devices, lists what you need to get started, describes optional equipment, and explains how to unpack your device.

## About the 6602 Devices

---

Thank you for buying a National Instruments 6602 device. The 6602 devices are timing and digital I/O boards for use with the PCI bus in PC-compatible computers, or PXI or compactPCI chassis. The 6602 devices offer eight 32-bit counter channels and up to 32 lines of individually configurable, TTL/CMOS-compatible digital I/O.

The counter/timer channels have many measurement and generation modes such as event counting, time measurement, frequency measurement, encoder position measurement, pulse generation, and square-wave generation.

The 6602 devices are completely switchless, jumperless DAQ devices for PCI buses and PXI or CompactPCI chassis, respectively. Both contain the National Instruments MITE PCI interface. The MITE offers bus-master operation, PCI burst transfers, and high-speed DMA controllers for continuous, scatter-gather DMA without requiring DMA resources from your computer. See the [Using PXI with CompactPCI](#) section in this chapter for more information on your PXI-6602 device.

For information on device functionality, see Chapter 3, [Device Overview](#). For detailed 6602 device specifications, see Appendix A, [Specifications](#).

## Using PXI with CompactPCI

---

Using PXI-compatible products with standard CompactPCI products is an important feature provided by the *PXI Specification*, rev. 1.0. If you use a PXI-compatible plug-in device in a standard CompactPCI chassis, you will be unable to use PXI-specific functions, but you can still use the basic plug-in device functions. For example, the RTSI bus on your PXI-6602 device is available in a PXI chassis, but not in a CompactPCI chassis.

The CompactPCI specification permits vendors to develop sub-buses that coexist with the basic PCI interface on the CompactPCI bus. Compatible operation is not guaranteed between CompactPCI devices with different sub-buses nor between CompactPCI devices with sub-buses and PXI. The standard implementation for CompactPCI does not include these sub-buses. Your PXI-6602 device will work in any standard CompactPCI chassis adhering to the PICMG CompactPCI 2.0 R2.1 document.

PXI specific features are implemented on the J2 connector of the CompactPCI bus. Table 1-1 lists the J2 pins used by your PXI-6602 device. Your PXI device is compatible with any CompactPCI chassis with a sub-bus that does not drive these lines. Even if the sub-bus is capable of driving these lines, the PXI device is still compatible as long as those pins on the sub-bus are disabled by default and not ever enabled. Damage may result if these lines are driven by the sub-bus.

**Table 1-1.** Pins Used by the PXI-6602 Device

PXI-6602 Signal	PXI Pin Name	PXI J2 Pin Number
RTSI Trigger (0..5)	PXI Trigger (0..5)	B16, A16, A17, A18, B18, C18
RTSI Trigger (6)	PXI Star	D17
RTSI Clock	PXI Trigger (7)	E16
Reserved	LBR (7, 8, 10, 11, 12)	A3, C3, E3, A2, B2

## What You Need to Get Started

---

To set up and use your 6602 device, you will need the following:

- One of the following devices:
  - PCI-6602
  - PXI-6602
- [PCI/PXI-6602 User Manual](#)

- One of the following software packages and documentation:
  - NI-DAQ for PC compatibles
  - LabVIEW for Windows
  - LabWindows/CVI
- Shielded (SH68-68-D1) or ribbon (R6868) cable
- SCB-68, TBX-68, or CB-68LP connector block
- Your computer, or a PXI or CompactPCI chassis and controller

## Unpacking

---

Your 6602 device is shipped in an antistatic package to prevent electrostatic damage to the device. Electrostatic discharge can damage several components on the device. To avoid such damage in handling the device, take the following precautions:

- Ground yourself via a grounding strap or by holding a grounded object.
- Touch the antistatic package to a metal part of your computer chassis before removing the device from the package.
- Remove the device from the package and inspect the device for loose components or any sign of damage. Notify National Instruments if the device appears damaged in any way. *Do not* install a damaged device into your computer.
- *Never* touch the exposed pins of connectors.

Store your 6602 device in the antistatic envelope when not in use.

## Software Programming Choices

---

There are several options to choose from when programming your National Instruments DAQ hardware. You can use LabVIEW, LabWindows/CVI, or NI-DAQ.

## National Instruments Application Software

LabVIEW features interactive graphics, a state-of-the-art user interface, and a powerful graphical programming language. The LabVIEW Data Acquisition VI Library, a series of VIs for using LabVIEW with National Instruments DAQ hardware, is included with LabVIEW. The LabVIEW Data Acquisition VI Library is functionally equivalent to the NI-DAQ software.

LabWindows/CVI features interactive graphics and a state-of-the-art user interface, and uses the ANSI standard C programming language. The LabWindows/CVI Data Acquisition Library, a series of functions for using National Instruments DAQ hardware, is included with LabWindows/CVI. The LabWindows/CVI Data Acquisition Library is functionally equivalent to the NI-DAQ software.

Using LabVIEW or LabWindows/CVI software will greatly reduce the development time for your data acquisition and control application.

## NI-DAQ Driver Software

The NI-DAQ driver software is included at no charge with all National Instruments DAQ hardware. NI-DAQ has an extensive library of functions that you can call from your application programming environment. These functions include routines for digital I/O, counter/timer operations, RTSI, and acquiring data to extended memory.

NI-DAQ has both high-level DAQ I/O functions for maximum ease of use and low-level DAQ I/O functions for maximum flexibility and performance. Examples for high-level functions are streaming data to disk or acquiring a certain number of data points. An example of a low-level function is writing directly to registers on the DAQ device. NI-DAQ does not sacrifice performance of National Instruments DAQ devices because it lets multiple devices operate at their peak performance, even simultaneously.

NI-DAQ also internally addresses many of the complex issues between the computer and the DAQ hardware such as programming interrupts and DMA controllers. NI-DAQ maintains a consistent software interface so that you can change platforms with minimal modifications to your code. Whether you are using conventional programming languages or NI-DAQ software, your application uses the NI-DAQ driver software, as illustrated in Figure 1-1.

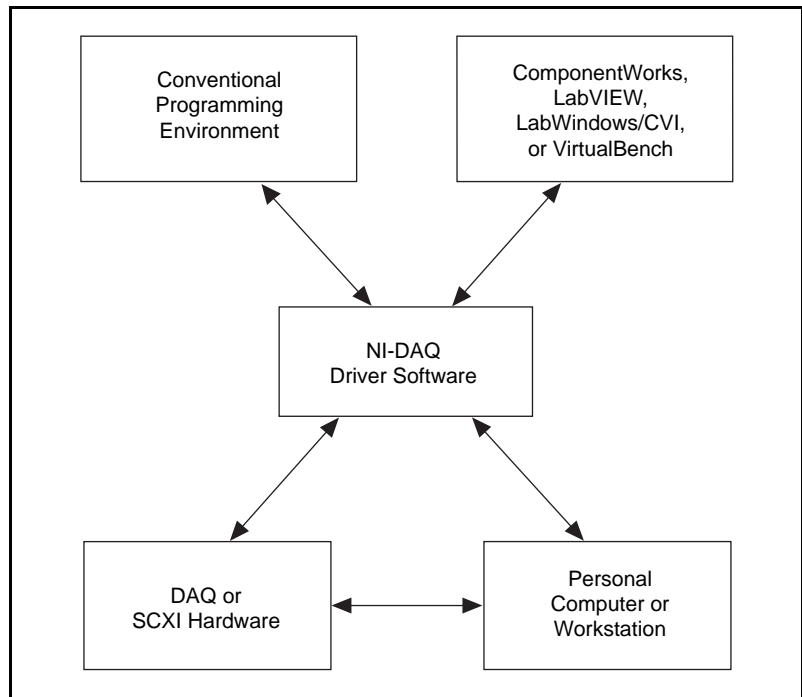

**Figure 1-1.** The Relationship between the Programming Environment, NI-DAQ, and Your Hardware

You can use your 6602 device, together with other AT (16-bit ISA), PCI, PC, EISA, DAQCard, and DAQPad Series DAQ hardware, with NI-DAQ software for PC compatibles. The PCI-6602 and PXI-6602 require version 6.5 or later.



## Optional Equipment

---

National Instruments offers the following accessories to use with your 6602 device:

- Shielded and unshielded 68-pin cables and screw terminals
- Real Time System Integration (RTSI) bus cables

For more specific information about these products, refer to your National Instruments catalogue or web site, or call the office nearest you.

---

# Installation and Configuration

This chapter explains how to install and configure your 6602 device.

## Software Installation

---

*Install your software before you install your 6602 device. Refer to the appropriate release notes indicated below for specific instructions on the software installation sequence.*

If you are using NI-DAQ, refer to your NI-DAQ release notes. Find the installation section for your operating system and follow the instructions given there.

If you are using LabVIEW or LabWindows/CVI, refer to the appropriate release notes. After you have installed your application software, refer to your NI-DAQ release notes and follow the instructions given there for your operating system and application software package.

## Hardware Installation

---

Following are general installation instructions for each device. Consult your computer or chassis user manual or technical reference manual for specific instructions about installing new devices in your computer or chassis.

◆ PCI-6602

You can install a PCI-6602 in any available 5 V PCI expansion slot in your computer.

1. Turn off and unplug your computer.
2. Remove the top cover or access port to the expansion slots.
3. Remove the expansion slot cover on the back panel of the computer.
4. Touch any metal part of your computer chassis to discharge any static electricity that might be on your clothes or body.

5. Insert the PCI-6602 into a 5 V PCI slot. It may be a tight fit, but *do not force* the device into place.
6. Screw the mounting bracket of the PCI-6602 to the back panel rail of the computer.
7. Visually verify the installation.
8. Replace the top cover of your computer.
9. Plug in and turn on your computer.

Your PCI-6602 installation is complete. The device is now ready for software configuration.

◆ PXI-6602

You can install a PXI-6602 in any available 5 V peripheral slot in your PXI or CompactPCI chassis.



**Note**

***The PXI-6602 has connections to several reserved lines on the CompactPCI J2 connector. Before installing a PXI-6602 in a CompactPCI system that uses J2 connector lines for purposes other than PXI, see the [Using PXI with CompactPCI](#) section in Chapter 1, Introduction.***

1. Turn off and unplug your PXI or CompactPCI chassis.
2. Choose an unused PXI or CompactPCI 5 V peripheral slot. For maximum performance when using a non-PXI chassis, install the PXI-6602 in a slot that supports bus arbitration or bus-master cards. The PXI-6602 contains onboard bus-master DMA logic that can operate only in such a slot. If you choose a slot that does not support bus masters, you will have to disable the onboard DMA controller using your software. PXI-compliant chassis must have bus arbitration for all slots.
3. Remove the filler panel for the peripheral slot you have chosen.
4. Touch a metal part on your chassis to discharge any static electricity that might be on your clothes or body.
5. Insert the PXI-6602 in the selected 5 V slot. Use the injector/ejector handle to fully inject the device into place.
6. Screw the front panel of the PXI-6602 to the front panel mounting rails of the PXI or CompactPCI chassis.
7. Visually verify the installation.
8. Plug in and turn on the PXI or CompactPCI chassis.

Your PXI-6602 installation is complete. The device is now ready for software configuration.

## PCI and PXI Device Configuration

---

The PCI-6602 and PXI-6602 are completely software configurable. The system software automatically allocates all device resources, including base memory address and interrupt level. These devices do not require DMA controller resources from your computer. You must assign a device number to your 6602 device. Double-click on the **Measurement & Automation** icon to assign a device number to your device. The Measurement & Automation Explorer has online help if you need more information on how to assign a device number. Refer to device configuration instructions in your NI-DAQ documents and online help.

---

# Device Overview

This chapter provides an overview of the hardware functions of your 6602 device.

## Device Description

---

The 6602 devices derive most of their functionality from the NI-TIO, a sophisticated, state-of-the-art counter and digital I/O ASIC developed by National Instruments. Each 6602 device has two NI-TIOs and offers eight 32-bit counters with prescalers (see Appendix C, *Block Diagram* for architecture of a 6602 device). The counters on 6602 devices are a superset of the general-purpose counters on the DAQ-STC. The DAQ-STC counters are used on all National Instruments E Series devices.

The 6602 counters offer backward compatibility with the DAQ-STC in regard to functionality and software programming. The same software API and functions are used to program the DAQ-STC general-purpose counters and the counters on the 6602 devices. Because of greater resources and added functionality, new constants, parameters, and functions have been created for 6602 counters. However, new functions exist to effect new functionality only—they will not affect code written for the DAQ-STC counters. In most cases, code written for the counter pair in the DAQ-STC general-purpose counters will work for the 6602 counters.

The few changes needed within the National Instruments API are mostly due to different constants for I/O connector signals (PFI lines). For example, E Series devices can select any of PFI <0..9> as a source for the general-purpose counters. For 6602 devices, the corresponding choices include PFI\_39, PFI\_35, and so on.

The counters on the 6602 devices have three internal timebases: 100 kHz, 20 MHz, or 80 MHz. Each counter has a gate, up/down, and source input. Each of these inputs can be an internal signal or an external signal that connects to the I/O connector. Each counter has an output signal that can provide output in two different modes. You can control the counters, which offer many useful features, via software or hardware. Each 6602 device is a completely switchless, jumperless device and requires only software configuration.

In addition, the NI-TIO provides the PCI-6602 with a 32-bit digital I/O (DIO) port. You can individually configure each line on this port for input or output and perform a read or a write upon a software command. Eight of these 32 lines are always available for DIO. The remaining 24 lines are shared with counters. You can configure these 24 lines for counter output or DIO output on an individual basis. You do not need to specify whether you are using the line for a counter application or for DIO if you are using it as an input.

Equipped with the NI-TIO, 6602 devices also have other useful functions such as ability to decode signals from motion encoders, and digital filtering on each line from the I/O connector.

With 6602 devices, you can use your computer or chassis as a counter/timer that acts as a system timing controller or measurement instrument for laboratory testing, production testing, and industrial process monitoring and control.

## Functionality

---

This section describes the 6602 counter applications and other miscellaneous functionality that these devices offer.

### Counter Applications

You can use the 6602 device in the counter-based applications listed in Table 3-1. Following the table are detailed descriptions of each application.

**Table 3-1.** Counter-Based Applications

Application Class	Application
Simple Counting and Time Measurement	Simple event counting Gated-event counting Single-period measurement Single pulse-width measurement Two-signal edge-separation measurement
Simple Pulse and Pulse-Train Generation	Single pulse generation Single triggered pulse generation Retriggerable single pulse generation Continuous pulse-train generation Frequency shift keying (FSK)

**Table 3-1.** Counter-Based Applications (Continued)

Application Class	Application
Buffered Counting and Time Measurement	Buffered event counting (continuous) Buffered period measurement (continuous) Buffered semi-period measurement (continuous) Buffered pulse-width measurement (continuous) Buffered two-signal edge-separation measurement (continuous)
Other Counter Applications	Pulse generation for Equivalent Time Sampling (ETS) Buffered periodic event counting (continuous) Frequency measurement Buffered frequency measurement (continuous) Finite pulse-train generation Frequency division Reciprocal frequency measurement
Position Measurement	Quadrature encoders Two-pulse encoders
Miscellaneous Functions	Filters Flexible period and frequency measurements Digital I/O Prescaling Simultaneous arming of counters Pad synchronization Synchronous counting mode

## Simple Counting and Time Measurement

### Event Counting

In the event-counting functions, the counter counts events on the SOURCE input after the counter has been armed. The counter can be armed via a software command or upon receiving a start trigger. The start trigger can be an internal or external signal. The following actions are available in event counting:

- SOURCE increments or decrements the counter.
- GATE may be used to indicate when to start and stop counting intervals or when to save the counter contents in the save register.
- UP\_DOWN controls the direction of the counting. When configured for hardware control of counting direction, the counter counts up when UP\_DOWN is high and it counts down when UP\_DOWN is low.

## Simple Event Counting

In simple event counting, the counter counts the number of pulses that occur on the SOURCE signal after the counter has been armed. Software can read the counter contents at any time without disturbing the counting process. Figure 3-1 shows an example of simple event counting where the counter counts five events on SOURCE.

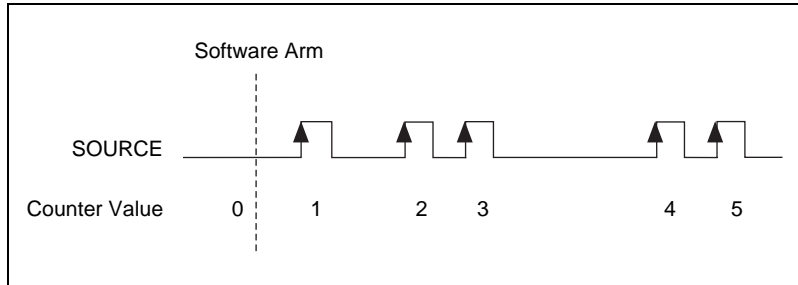

Figure 3-1. Simple Event Counting

## Gated-Event Counting

Gated-event counting is similar to simple event counting except that the counting process is gated; counting is halted and resumed via the GATE signal. When GATE is active, the counter counts pulses that occur on the SOURCE signal after the counter has been armed. When GATE is inactive, the counter retains the current count value. Figure 3-2 shows an example of gated-event counting where the gate action allows the counter to count only five of the pulses on SOURCE.

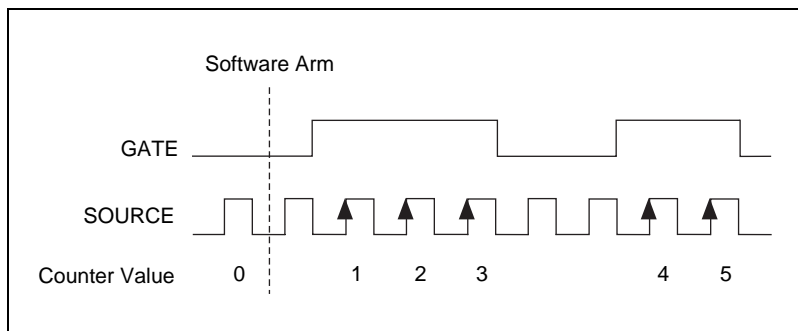

Figure 3-2. Gated-Event Counting



## Time Measurement

In the time-measurement functions, the counter uses SOURCE as a timebase to measure the time interval between events on the GATE signal. The following actions are available in time measurement:

- Rising edges on SOURCE can increment or decrement the counter during the measurement interval. Typically, SOURCE is chosen to be an internal timebase and causes the counter to increment.
- Counting can begin and end on any two of the GATE edges—active, inactive, or either.
- The HW Save register can save the counter value upon the completion of the measurement.

### Single-Period Measurement

In single-period measurement, the counter uses SOURCE to measure the period of the signal present on the GATE input. The counter counts the number of rising edges that occur on SOURCE between two active edges of GATE. At the completion of the period interval for GATE, the HW Save register latches the counter value for the software read. Figure 3-3 shows a single-period measurement where the period of GATE is five SOURCE rising edges.

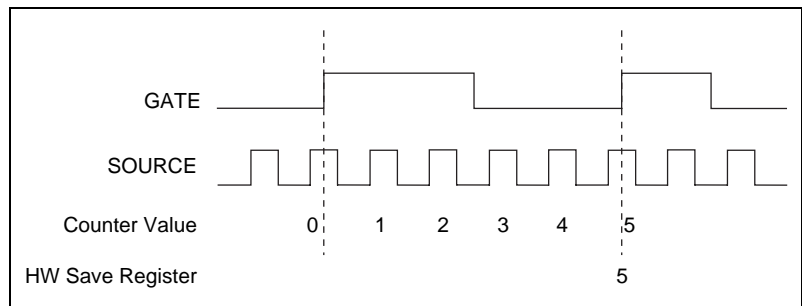

**Figure 3-3.** Single-Period Measurement

### Single Pulse-Width Measurement

In single pulse-width measurement, the counter uses SOURCE to measure the pulse width of the signal present on the GATE input. The counter counts the number of rising edges that occur on SOURCE while the GATE signal remains in an active state. At the completion of the pulse-width interval for GATE, the HW Save register latches the counter value for software read. Figure 3-4 shows a single pulse-width measurement where the pulse width of GATE is five SOURCE rising edges.



**Note**

*A pulse width measurement will be accurate even if the counter is armed while a pulse train is in progress. If a counter is armed while the pulse is in the active state, it will wait for the next transition to the active state for the measurement.*

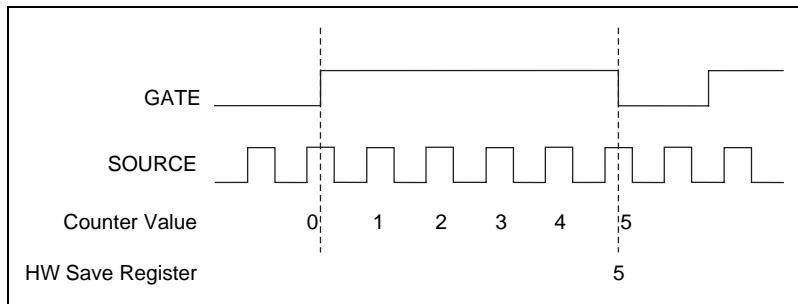
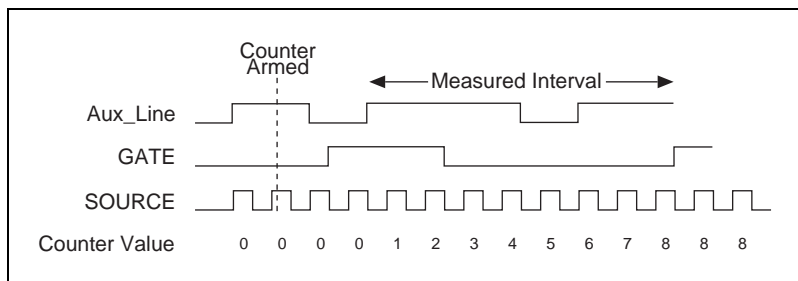

**Figure 3-4.** Single Pulse-Width Measurement

### Two-Signal Edge-Separation Measurement

Two-signal edge-separation measurement is similar to pulse-width measurement, except that there are two measurement signals: AUX\_LINE and GATE. An active edge on AUX\_LINE starts the counting and an active edge on GATE stops the counting. After the counter has been armed and an active edge has occurred on AUX\_LINE, the counter counts pulses that occur on the SOURCE. Additional edges on the AUX\_LINE are ignored. The counter stops counting upon receiving an active edge on the GATE and latches the value into the HW Save register. Figure 3-5 shows an example of two-signal edge-separation measurement.

You can use this type of measurement to count events or measure the time that occurs between edges on two signals. The AUX\_LINE and GATE can be internal or external signals. For external signals, the Up\_Down pin associated with the counter is used for the AUX\_LINE.



**Figure 3-5.** Two-Signal Edge-Separation Measurement

## Simple Pulse and Pulse-Train Generation

### Simple Pulse Generation

In the pulse generation functions, the counter generates a single pulse of a specified duration after the counter is armed. The following actions are available in pulse generation:

- The counter uses SOURCE as a timebase to generate the pulse.
- The user specifies the pulse parameters in terms of periods of the SOURCE input.
- GATE can serve as a trigger signal to generate a pulse after the first active gate edge, or after each active gate edge.
- The hardware provides an alternate output mode so that G\_OUT outputs two counter TC pulses, instead of a single long pulse.

Two output modes are available on the 6602 counters: toggled output mode and pulsed output mode. Each time a counter rolls over from either direction, it generates a pulse known as the terminal count (TC) pulse. In pulsed mode, this TC pulse is driven onto the output pin.

In toggled mode, the counter output changes state on the SOURCE edge that follows the assertion of the TC pulse. Figure 3-6 illustrates the two output modes for a pulse generation with a delay of four and a pulse width of six.

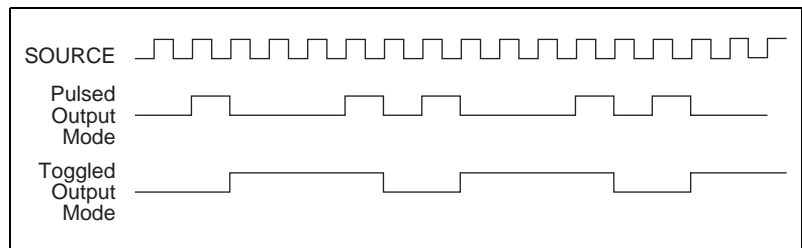

**Figure 3-6.** Output Modes

### Single Pulse Generation

The single pulse-generation function generates a single pulse with programmable delay and programmable pulse width after the counter is armed. The counter uses SOURCE as a timebase to generate the pulse—you specify the pulse delay and the pulse width in terms of periods of the SOURCE input. Figure 3-7 shows the generation of a single pulse with a pulse delay of four and a pulse width of three.

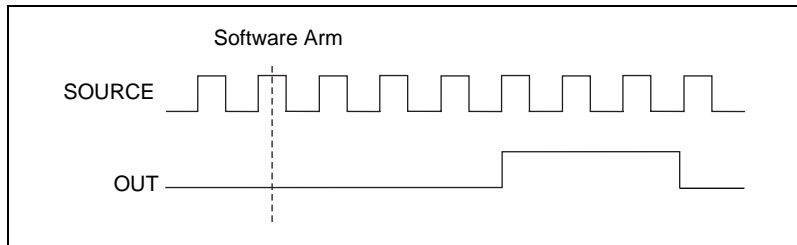

**Figure 3-7.** Single Pulse Generation

### Single-Triggered Pulse Generation

Single-triggered pulse generation is similar to single pulse generation except that GATE provides a trigger function. An active GATE edge after the counter has been armed causes the counter to generate a single pulse with programmable delay and programmable pulse width. The counter ignores subsequent triggers. You specify the programmable parameters in terms of periods of the SOURCE input. Figure 3-8 shows the generation of a single pulse with a pulse delay of four and a pulse width of three.

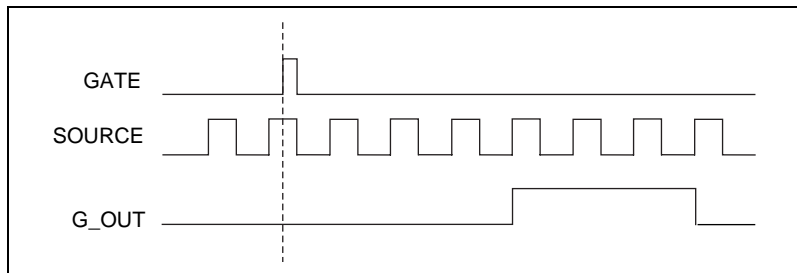

**Figure 3-8.** Single-Triggered Pulse Generation

### Retriggerable Single Pulse Generation

This function is similar to single-triggered pulse generation except that the counter generates a pulse on every active GATE edge after the counter has been armed. The counter ignores active gate edges that are received while the pulse generation is in progress. Each pulse, thus generated upon receiving a GATE edge, has the same programmable delay and pulse width. You specify these parameters in terms of periods of the SOURCE input. Figure 3-9 shows the generation of two pulses with a pulse delay of five and a pulse width of three.

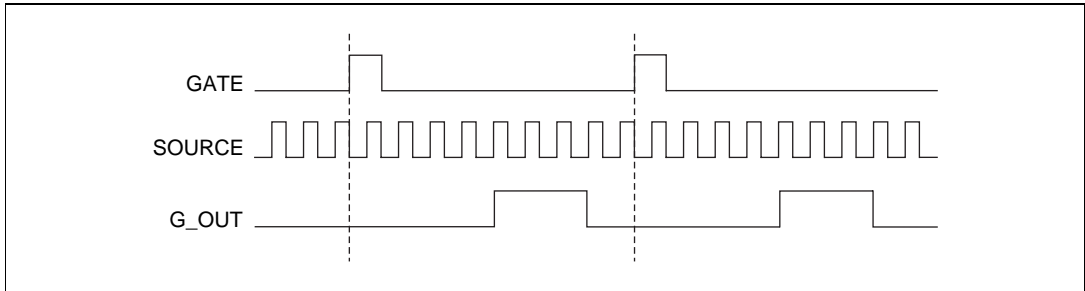

**Figure 3-9.** Retriggerable Single Pulse Generation

## Pulse-Train Generation

In the pulse-train generation functions, the counter generates a continuous stream of pulses of specified interval and duration after the counter has been armed. The following actions are available in pulse-train generation:

- You can specify the pulse parameters in terms of periods of the SOURCE input.
- The hardware has an alternate output mode as explained in the [Simple Pulse Generation](#) section.



### Note

*With a 50% duty cycle pulse train, you double the frequency if you use the pulsed output mode.*

## Continuous Pulse-Train Generation

This function generates a train of pulses with programmable frequency and duty cycle. The counter uses SOURCE as a timebase to generate the pulses. You specify the programmable parameters in terms of periods of the SOURCE input. Figure 3-10 shows a pulse-train. You can seamlessly change the frequency of the pulse train while the pulse train is in progress. The rate at which you can change the frequency depends on your system.

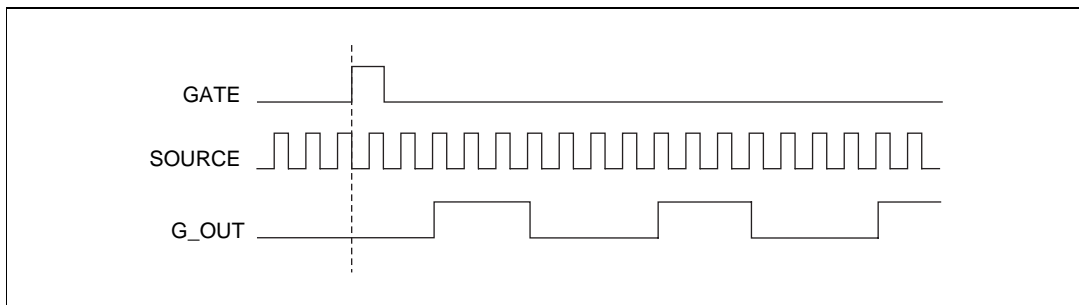

**Figure 3-10.** Continuous Pulse-Train Generation

### Frequency Shift Keying (FSK)

FSK is similar to pulse-train generation in that the counter generates a train of pulses. However, in FSK mode, the GATE signal modulates the frequency and duty cycle of the output train. The counter implements this modulation by allowing the GATE signal to select from two different sets of pulse-train parameters. Figure 3-11 shows an example of FSK. When GATE is low, the counter generates a low-frequency signal with a long pulse width. When GATE is high, the counter generates a high-frequency signal with a short pulse width.

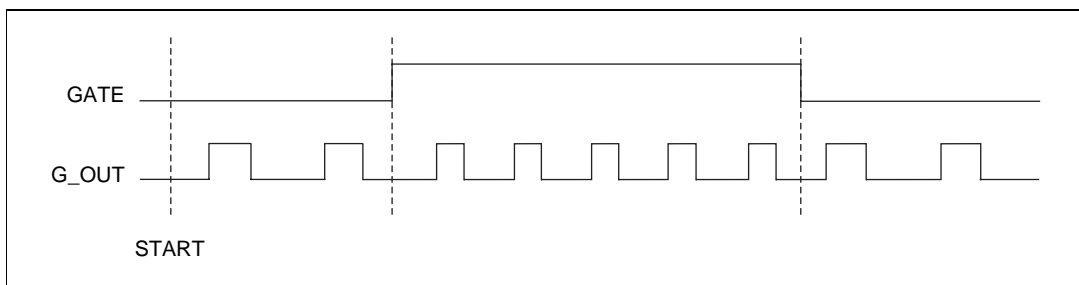

**Figure 3-11.** Frequency Shift Keying

### Buffered Counting and Time Measurements

Buffered measurements are similar to their single measurement counterparts except that multiple consecutive measurements are made. The result of each measurement is saved in the HW Save register on each active edge of GATE. The measurements are then transferred to your computer via DMA or interrupts. *These buffered measurements can be continuous.*

If your buffered measurement requires an external signal to drive the SOURCE signal of your counter, you should use the synchronous counting mode. See the *Synchronous Counting Mode* section for additional details.

## Buffered Event Counting

Buffered event counting is similar to simple event counting except that the GATE signal indicates when to save the counter value to the HW Save register. The active GATE edge latches the count value into the HW Save register. Counting continues uninterrupted regardless of the GATE activity. Figure 3-12 shows buffered event counting where the GATE action causes the HW Save register to save the counter contents twice.

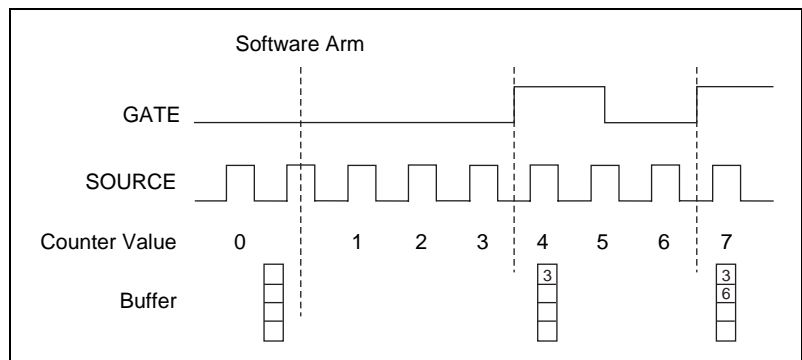

Figure 3-12. Buffered Event Counting

## Buffered Period Measurement

Buffered period measurement is similar to single-period measurement, except that measurements are taken for multiple periods. The counter measures the period of the signal present on the GATE input by counting the number of rising edges that occur on SOURCE between each pair of active edges of GATE. At the completion of each period interval for GATE, the HW Save register latches the counter value for software read. Figure 3-13 shows two periods of a buffered period measurement where the period is three SOURCE rising edges.

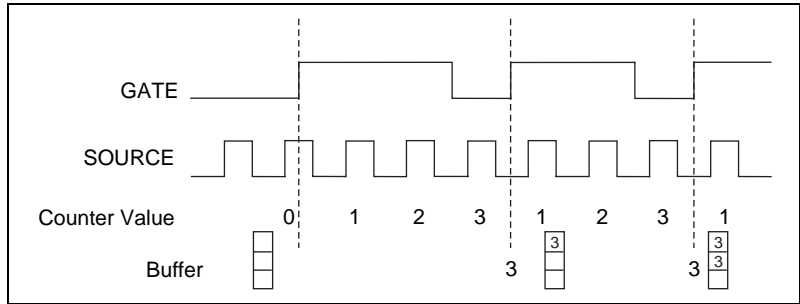

Figure 3-13. Buffered Period Measurement

### Buffered Semiperiod Measurement

Buffered semiperiod measurement is similar to buffered period measurement, except that the measurements are taken over every semiperiod. The counter measures each half-period of the signal present on the GATE input by counting the number of rising edges that occur on SOURCE while GATE remains in each state.

At the completion of each semiperiod interval for GATE, the HW Save register latches the count value for software read. Figure 3-14 shows three semiperiods of a buffered semiperiod measurement where the first semiperiod is three SOURCE rising edges, the second semiperiod is one SOURCE rising edge, and the final semiperiod is two SOURCE rising edges. *The first measurement is made on the first active phase of the cycle, which you specify, after the counter is armed.*

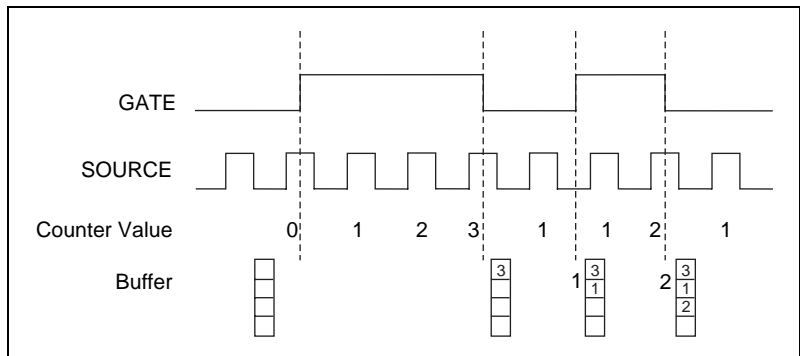

Figure 3-14. Buffered Semiperiod Measurement



## Buffered Pulse-Width Measurement

Buffered pulse-width measurement is similar to single pulse-width measurement, except that the measurements are taken over multiple consecutive pulses. The counter measures the pulse width of the signal present on the GATE input by counting the number of rising edges that occur on SOURCE while GATE remains in an active state.

At the completion of each pulse-width interval for GATE, the HW Save register latches the counter value for software read. Figure 3-15 shows two pulse widths of a buffered pulse-width measurement where the first pulse width is three SOURCE rising edges and the second pulse width is two SOURCE rising edges.



### Note

*The first measurement will be correct even if the pulse train is in progress when the counter is armed. If the counter is armed while the GATE is in the active state, the measurement will begin with the next transition into the active state.*

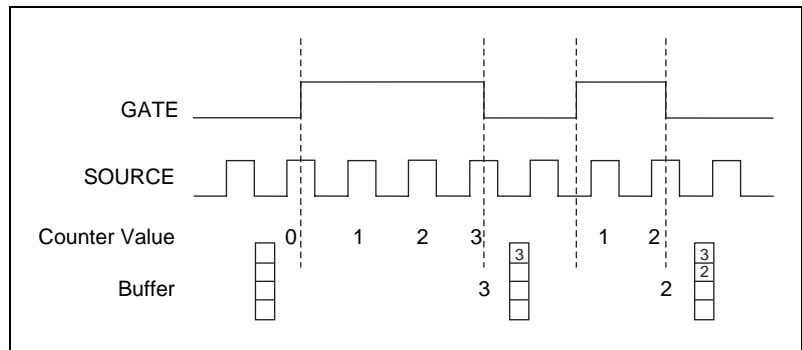
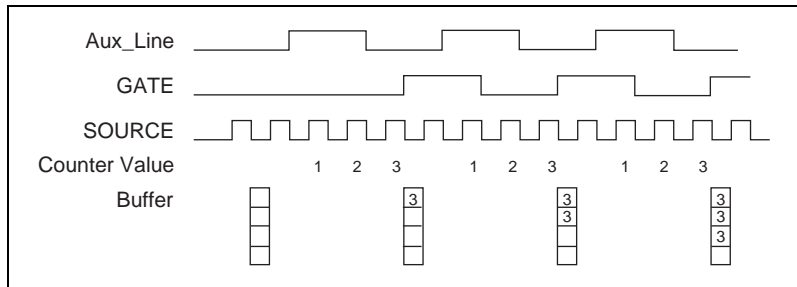

Figure 3-15. Buffered Pulse-Width Measurement

## Buffered Two-Signal Edge-Separation Measurement

Buffered two-signal edge-separation measurement is similar to its single measurement counterpart, except that measurements are taken for multiple periods. The counter counts the number of rising edges on SOURCE between the active edge of AUX\_LINE and the following active edge of GATE. At each active edge of GATE, the HW Save register latches the counter value for software read. Figure 3-16 shows three instances of buffered two-signal edge-separation measurement where the separation is three SOURCE rising edges.



**Figure 3-16.** Buffered Two-Signal Edge-Separation Measurement

## Other Counter Applications

### Pulse Generation for ETS

In this application, the counter produces a pulse on the output a specified delay after an active edge on GATE. After each active edge on GATE, the counter cumulatively increments the delay between the GATE and the pulse on the output by a specified amount. Thus, the delay between the GATE and the pulse produced successively increases.

The increase in the delay value can be between 0 and 255. For instance, if you specify the increment to be 10, the delay between the active GATE edge and the pulse on the output will increase by 10 every time a new pulse is generated.

Suppose you program your counter to generate pulses with a delay of 100 and pulse width of 200 each time it receives a trigger. Furthermore, suppose you specify the delay increment to be 10. On the first trigger, your pulse delay will be 100, on the second it will be 110, on the third it will be 120; the process will repeat in this manner until the counter is disarmed. The counter ignores any GATE edge that is received while the pulse triggered by the previous GATE edge is in progress.

The waveform thus produced at the counter's output can be used to provide timing for undersampling applications where a digitizing system can sample repetitive waveforms that are higher in frequency than the Nyquist frequency of the system. Figure 3-17 shows an example of pulse generation for ETS; the delay from the trigger to the pulse increases after each subsequent GATE active edge.

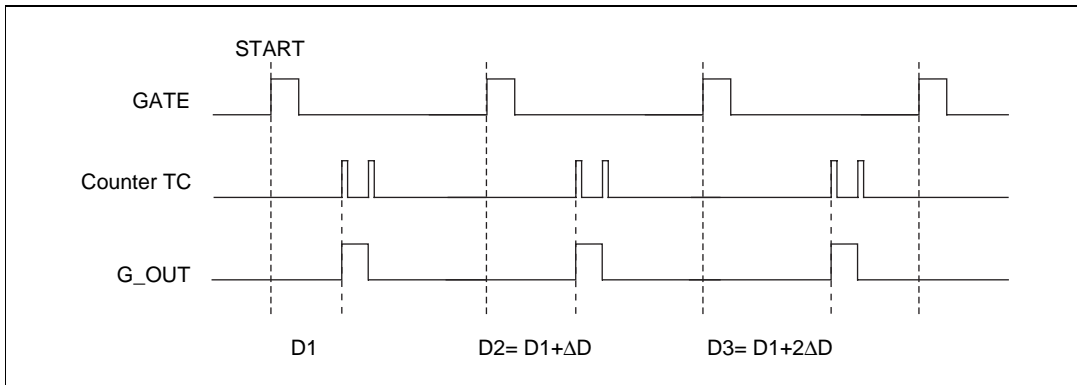

Figure 3-17. Pulse Generation for ETS

### Buffered Periodic Event Counting

Buffered periodic event counting is similar to simple event counting except that there are multiple consecutive counting intervals. The GATE signal indicates the boundary between consecutive counting intervals. The counter begins to count after the first active edge on GATE. Each active edge of the GATE signal latches the count value for the current counting interval into the HW Save register and reloads the counter with the initial value to begin the next counting interval. Figure 3-18 shows buffered periodic event counting with two counting intervals. Three events are counted in each of the two counting intervals.

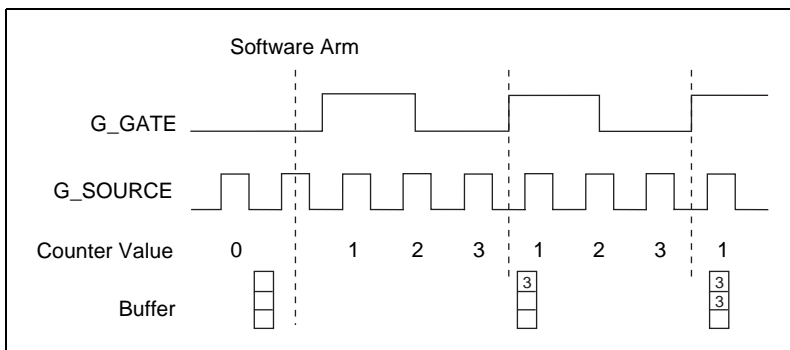

Figure 3-18. Buffered Periodic Event Counting

## Frequency Measurement

For frequency measurement, a pulse of known width or a waveform of known frequency and duty cycle is applied to the GATE of the counter. The signal to be measured is applied to the SOURCE of the counter. The counter counts how many SOURCE edges are received during the gated interval. The frequency is the number of counts divided by the duration of GATE in *seconds*, as shown in Figure 3-19.

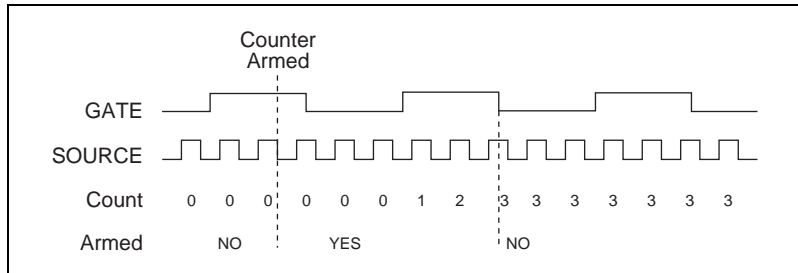

Figure 3-19. Frequency Measurement

## Buffered Frequency Measurement

For this measurement, a pulse train of known pulse width is applied to the GATE of the counter. The signal to be measured is applied to the SOURCE of the counter. The counter counts how many source edges are received during each active phase of the pulse train at its GATE. At each inactive edge of GATE, the HW Save register latches the counter value for software read. Figure 3-20 shows an example of buffered frequency measurement.

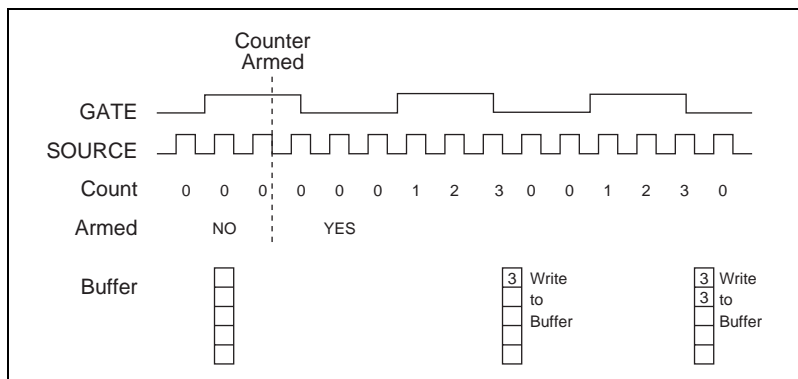

Figure 3-20. Buffered Frequency Measurement

## Finite Pulse-Train Generation

In this application, the counter generates a specified number of pulses as indicated in Figure 3-21. The high and low phase of the pulse train are programmable. These values are specified in multiples of the timebase that is used as the SOURCE of the counter. Figure 3-21 shows two pulses with a pulse delay of two and a pulse width of three. Two counters are used for this application.

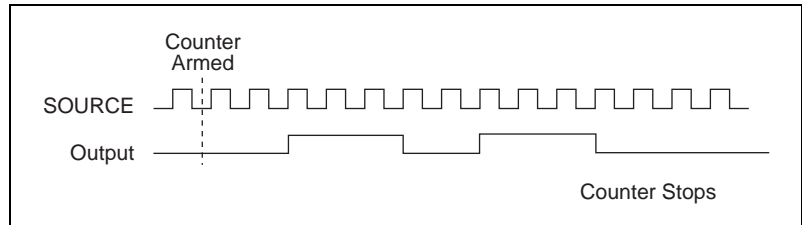

Figure 3-21. Finite Pulse-Train Generation

## Frequency Division

In this application, the counter divides the frequency of the signal connected to its SOURCE input. The divided signal appears on its OUT. Figure 3-22 shows a frequency division ratio of six.

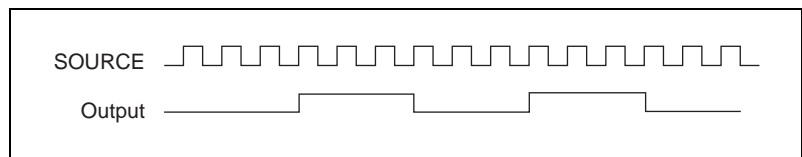
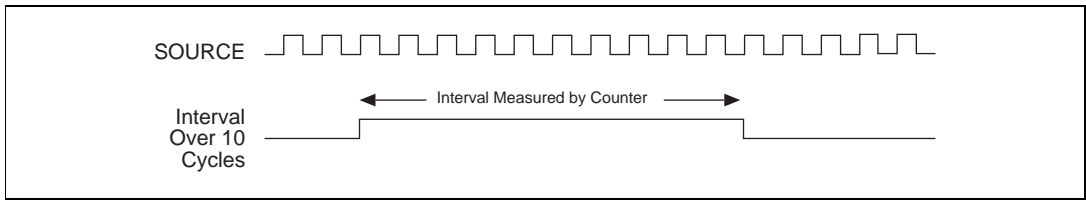

Figure 3-22. Frequency Division

## Reciprocal Frequency Measurement

In this measurement, you must use two counters to determine the frequency. First, measure the time over an integer number of cycles of the signal to be measured. Then, divide the total time by the number of cycles to obtain a value for the period of the signal. The frequency is the inverse of the period. Figure 3-23 illustrates this measurement. The number of cycles for the interval measurement is specified to be 10. The period of the signal is the interval divided by 10.



**Figure 3-23.** Reciprocal Frequency Measurement

## Position Measurement

The 6602 devices can perform position measurements on signals from two types of motion encoders:

- Quadrature encoders (X1, X2, and X4 encoding)
- Two-pulse encoders (also referred to as up/down encoders)

### Quadrature Encoders

A quadrature encoder can have up to three channels: channels A, B, and Z. When channel A leads channel B in a quadrature cycle, the counter increments. When channel B leads channel A in a quadrature cycle, the counter decrements. The amount of increments and decrements per cycle depends on the type of encoding: X1, X2, or X4.

Figure 3-24 shows a quadrature cycle and the resulting increments and decrements for X1 encoding. When channel A leads channel B, the increment occurs on the rising edge of channel A. When channel B leads channel A, the decrement occurs on the falling edge of channel A.

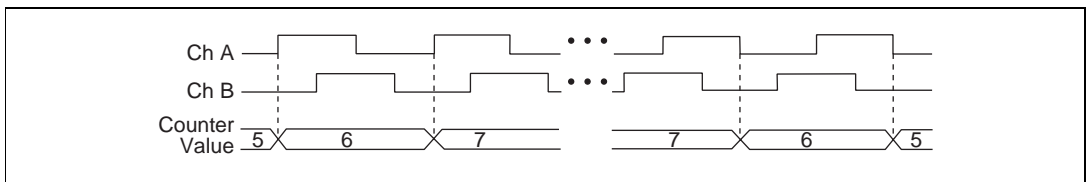

**Figure 3-24.** Position Measurement for X1 Encoders

The same behavior holds for X2 encoding except the counter increments or decrements on each edge of channel A, depending on which channel leads the other. Each cycle results in two increments or decrements, as shown in Figure 3-25.

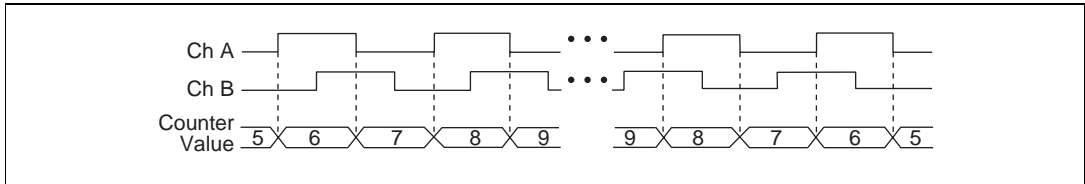

**Figure 3-25.** Position Measurement for X2 Encoders

Similarly, the counter increments or decrements on each edge of channels A and B for X4 encoding. Whether the counter increments or decrements depends on which channel leads the other. Each cycle results in four increments or decrements, as shown in Figure 3-26.

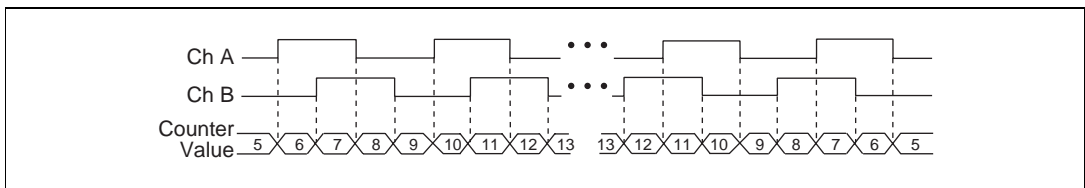

**Figure 3-26.** Position Measurement for X4 Encoders

Some quadrature encoders have a third channel, channel Z, which is also referred to as the index channel. A high level on channel Z causes the counter to be reloaded with a specified value in a specified phase of the quadrature cycle. You can program this reload to occur in any one of the four phases in a quadrature cycle.



**Note**

***In NI-DAQ version 6.5, channel Z reload can only occur when channels A and B are both low. The ability to reload in other phases will become available in a subsequent release.***

Channel Z behavior—when it goes high and how long it stays high—differs with quadrature encoder designs. You must refer to the documentation for your quadrature encoder to obtain timing of channel Z with respect to channels A and B. You must then ensure that channel Z is high during at least a portion of the phase you specify for reload. For instance, in Figure 3-27, channel Z is never high when channel A is high and channel B is low. Thus, the reload must occur in some other phase.

The reload phase is when both channel A and channel B are low. The reload occurs when this phase is true and channel Z is high. Incrementing and decrementing takes priority over reloading. Thus, when the channel B goes low to enter the reload phase, the increment occurs first. The reload occurs within one maximum timebase period after the reload phase becomes true.

After the reload occurs, the counter continues to count as before. Figure 3-27 illustrates channel Z reload with X4 decoding.

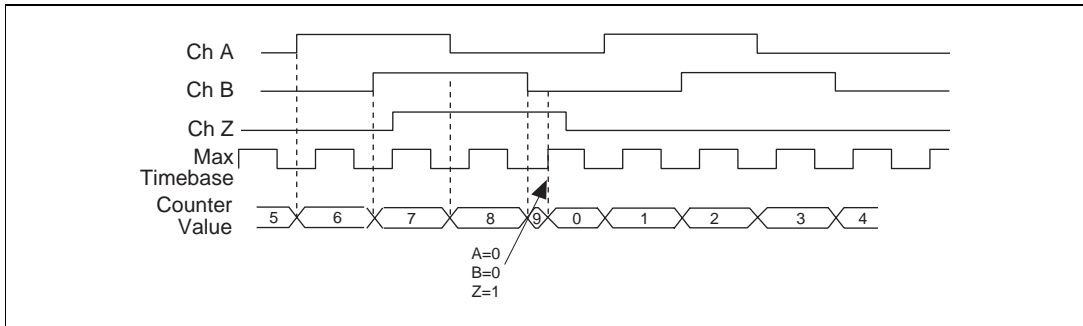

Figure 3-27. Channel Z Reload

## Two-Pulse Encoders

Two-pulse encoding supports two channels: channels A and B. A pulse on channel A causes the counter to increment on its rising edge. A pulse on channel B causes the counter to decrement on its rising edge, as shown in Figure 3-28.

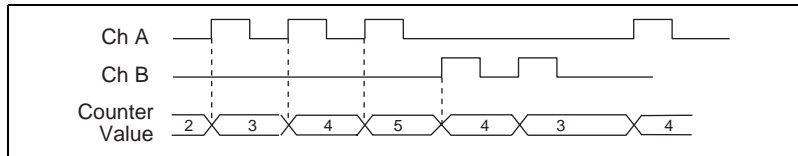

Figure 3-28. Two-Pulse Encoders

## Miscellaneous Functions

### Filters

Each PFI line coming from the I/O connector can be passed through a simple digital filter. The filter operates off a filter clock and a fast internal sampling clock. It samples the signal on the PFI line on each rising edge of the sampling clock. A change in the signal is propagated only if it maintains its new state for at least the duration between two consecutive rising edges of the filter clock. The frequency of the filter clock determines whether a transition in the signal may propagate or not. The function of the sampling clock is to increase the sampling rate and prevent aliasing. Figure 3-29 demonstrates the function of this filter.



In Figure 3-29, the low-to-high transition is guaranteed to be passed through only if the signal remains high for at least two filter clock periods and is sampled high at each sampling clock rising edge during this time. Although the low-to-high transition is shown in this example, the same is true for high-to-low transitions.



**Note** *The effect of filtering is that the signal transition is shifted by two filter clock periods.*

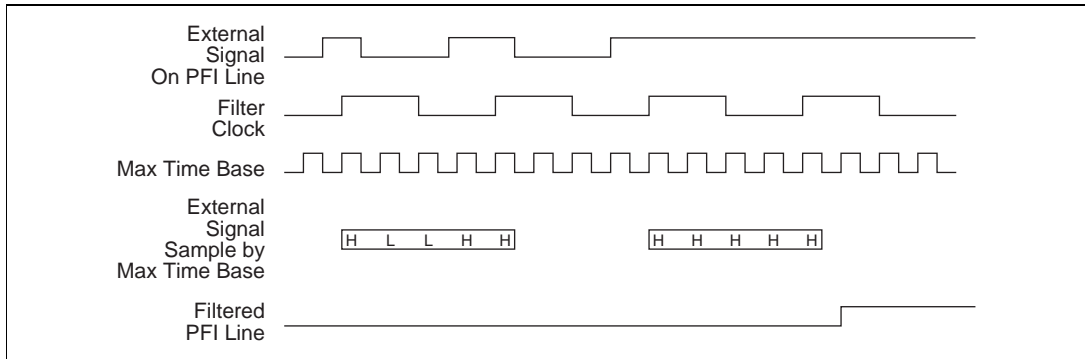

**Figure 3-29.** Filters

Figure 3-29 shows that if sampling was done at each rising edge of the filter clock alone, the first two pulses would have been seen as one continuous transition. However, using the faster sampling clock detects the glitch; thus, the two short pulses are ignored.

The intent of the filter is to eliminate glitches that may appear on a signal. The filter is sensitive to the duration for which a digital signal transitions from one state to another. Thus, if a square wave is applied to the filter, its propagation will depend on its frequency and duty cycle.

There are four filter settings available in the 6602 devices: 5  $\mu$ s, 1  $\mu$ s, 500 ns, and 100 ns. The 5  $\mu$ s filter will pass all pulse widths (high and low) that are 5  $\mu$ s or longer; it will block all pulse widths that are 2.5  $\mu$ s (one half of 5  $\mu$ s) or shorter. Pulse widths between 2.5  $\mu$ s and 5  $\mu$ s may or may not pass, depending on the phase of the pulse with respect to the filter clock. The same relationship extends to all other filter clocks.

In addition to these hard-wired filter clocks, you can use the output of any one of the counters as a filter clock. Configure the counter for pulse-train generation and use a pulse train with a duty cycle as near 50% as possible. The output of this counter is then selected as a filter clock.

If the frequency of this pulse train is  $f_{\text{filterclk}}$ , its period is  $t_{\text{filterclk}}$ . A filter using this filter clock guarantees to pass pulse widths that are  $2 * t_{\text{filterclk}}$  or longer and to block pulse widths that are  $t_{\text{filterclk}}$  or shorter. A pulse with a width between these two ranges may or may not pass, depending on the phase of the pulse with respect to the filter clock. You can also use a signal on the RTSI bus as a filter clock.

Table 3-2 summarizes the properties of the different filter settings.

**Table 3-2.** Properties of the Different Filter Settings

Filter Setting	Pulse Width Guaranteed to Pass	Pulse Width Guaranteed to Be Blocked
5 $\mu\text{s}$	5 $\mu\text{s}$	2.5 $\mu\text{s}$
1 $\mu\text{s}$	1 $\mu\text{s}$	500 ns
500 ns	500 ns	250 ns
100 ns	100 ns	50 ns
Programmable setting with period of clock = $t_{\text{filterclk}}$	$2 * t_{\text{filterclk}}$	$t_{\text{filterclk}}$

You individually configure the filter setting for each PFI line. The filters are useful to maintain signal integrity. They can prevent measurement errors caused by noise, crosstalk, or transmission line effects.

## Flexible Period and Frequency Measurements

You can obtain frequency by taking the inverse of a period measurement. Period measurement is more accurately performed on signals with lower frequencies. Consider a period measurement on a 50 kHz signal. This frequency corresponds to 400 cycles of a 50 ns timebase. Your measurement may return 399, 400, or 401 cycles depending on the phase of the signal with respect to the timebase. As your frequency becomes larger, this error of +1 or -1 cycle becomes more significant; Table 3-3 illustrates this point

**Table 3-3.** Period Measurements

Actual Frequency	Number of 50 ns Cycles	Measurement Error of +1 Cycle	Measurement Error of -1 Cycle	Frequency with Error of +1 Cycle	Frequency with Error of -1 Cycle
50 kHz	400	401	399	49.88 kHz	50.13 kHz
5 MHz	4	5	3	4 MHz	6.67 MHz

Suppose your acceptable percentage error of your measurement is  $0.x$  (where  $x$  is a decimal fraction). The maximum frequency you can measure through period measurement within this error range is given by:

$$F = F_{tb} - (F_{tb} / (1 + 0.x))$$

where  $F_{tb}$  is the frequency of your timebase.

You can make direct frequency measurements by gating a counter for a known period of time and counting the edges of your signal during that time. Unless you are able to provide this gating signal externally, you will need two counters for this measurement. The accuracy of the frequency measurement lowers as the frequency approaches low and high limits.

As frequencies become faster than the maximum source frequency your counter can accept, your measurement can become unreliable. Similarly, your measurements can be incorrect if the frequencies become slower. Suppose you are measuring the frequency of a 0.2 Hz signal by counting the number of pulses you get in one second. In this case, your measurement may return 0 or 1, thus giving frequencies of 0 Hz or 1 Hz. For lower frequencies, you will measure the period and take its inverse to obtain the frequency.

Thus, you measure frequencies by measuring the period. You use direct frequency measurement when the period measurement begins to exceed your acceptable margin of error. *Reciprocal frequency measurement* is another measurement technique that uses two counters to allow more accurate period and frequency measurements on high-speed signals by measuring the total time over a specified *integer* number of cycles of the signal being measured (with direct frequency measurement described above, you cannot account for fractions of cycles at the beginning and end of the GATE period).

You can then divide the total time by the number of cycles you measured over to calculate the period to greater accuracy than that given by a single measurement. The frequency is the inverse of the period.

The counters on 6602 devices allow great flexibility on GATE selection to facilitate period or frequency measurements on the same signal without requiring any change in hardware connections. Suppose you are using counter 1 to measure the period of a signal that varies over a broad range of frequencies. You should connect this signal to the PFI line that corresponds to the SOURCE of counter 1: PFI\_35. Table 4-2 shows the PFI lines and their functionality when used for counter applications.

For direct frequency measurement, select PFI 35 as the SOURCE of the counter. You need a signal of known parameters on the GATE of counter 1 for this measurement; counter 0 could be used to provide this signal.

For period measurements, select counter\_source as the GATE of counter 1, which selects PFI\_35 as GATE(1). An internal timebase is used as the SOURCE of counter 1. Thus, the signal on PFI 35 can be used as the GATE or the SOURCE of counter 1. *You would programmatically need to change the GATE and SOURCE selection of counter 1 as you switch between the two measurements.* Figure 3-30 shows counter 1 used for frequency and period measurements.

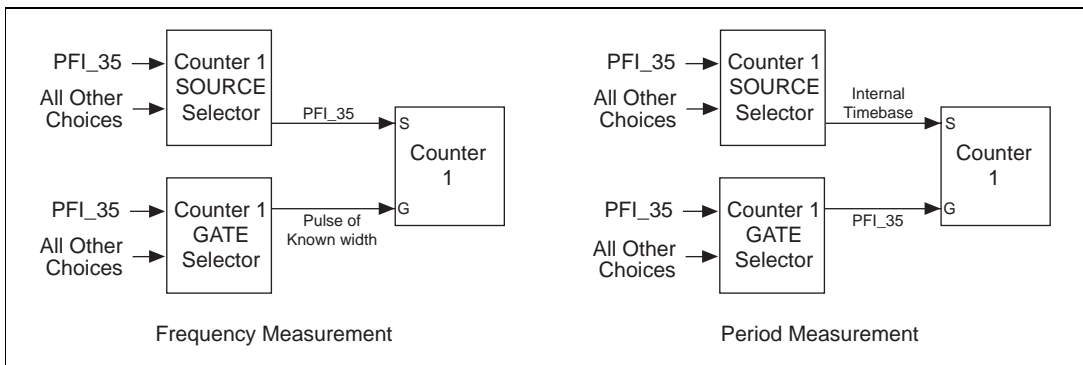

**Figure 3-30.** Counter1 Used for Frequency and Period Measurements

If you want to simultaneously measure the period and frequency of the signal, do as follows. If you are using counters 0 and 1 for these measurements, connect your signal to PFI 35. You will measure the frequency on counter 1 by using PFI 35 as its SOURCE and measure the period with counter 0 by using *other\_counter's\_source* as its GATE. Counter 0 will use an internal timebase as its SOURCE.

For the simultaneous measurement, you will need to use an external device or another counter to gate counter 1 for the frequency measurement. You can use counter 2 to produce this gate. To do so, route the output of counter 2 onto a RTSI line and use that RTSI line as the GATE of counter 1. If a RTSI line is not available, you can wire the output of counter 2 to the GATE of counter 1 on the I/O connector.

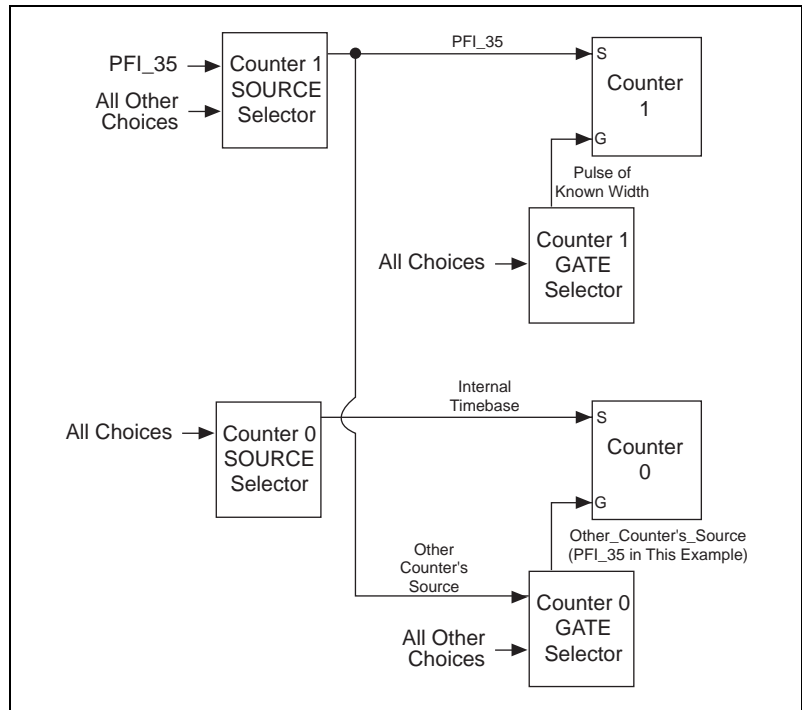

**Figure 3-31.** Counters 0 and 1 Used for Frequency and Period Measurements Simultaneously

The routing and gate selection options also allow convenient reciprocal frequency measurement.

## Digital I/O

Each PCI-6602 device has a 32-bit DIO port on PFI<0..31>. Digital I/O consists of asynchronous reads and writes to the digital port upon software command. You can individually configure each line for digital input or output. Also, PFI<8..31> can be individually configured for either counter associated output or digital I/O output. It is necessary to specify whether a PFI line is being used for counter I/O or digital I/O only if that line is being used as an output.

## Prescaling

Prescaling allows the counter to count a signal that is faster than the timebase of the counter. The PCI-6602 offers 8X and 2X prescaling on each counter (prescaling can be disabled). Each prescaler consists of a small, simple counter that counts to eight (or two) and rolls over. This counter can run faster than the larger counters, which simply count the roll-overs of this smaller counter. Thus, the prescaler acts as a frequency divider on the SOURCE and puts out a frequency that is one-eighth (or one-half) of what it is accepting.

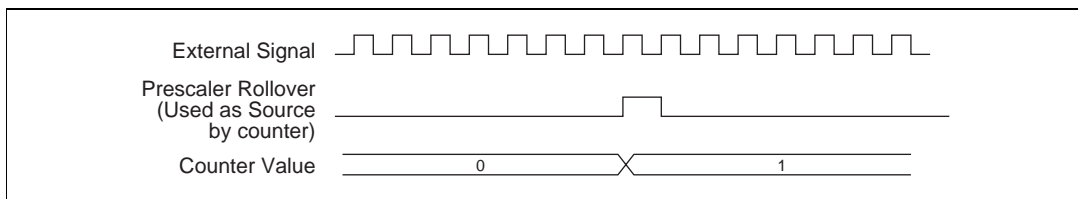

**Figure 3-32.** Prescaling

Prescaling is intended to be used for frequency measurement where the measurement is made on a continuous, repetitive signal. The prescaling counter cannot be read; therefore, you cannot determine how many edges have occurred since the previous roll-over. Prescaling can be used for event counting provided it is acceptable to have an error of up to seven (or one).

## Simultaneous Arming of Counters

Arm each counter through a software command or by a hardware start trigger. The start trigger may be an internal or an external signal. You can arm more than one counter simultaneously by configuring each to arm off the start trigger. However, you can choose only one start trigger.

## Pad Synchronization

The 6602 devices allow synchronization of its PFI lines and RTSI lines at the I/O pads. Pad synchronization is useful when several counters are measuring or operating off the same external signal. For example, suppose counters 0 and 1 are configured for triggered pulse generation and each counter uses the same external trigger (this external signal is connected to PFI\_38 on the I/O connector and both counters have PFI\_38 selected as their GATE.) After the trigger signal propagates through the I/O pad of the ASIC, the time for the signal to reach the GATE of each counter within the ASIC may differ by a few nanoseconds.

This signal is sampled at the counters' GATES using the selected SOURCE. Because of different propagation times for the paths to the two GATES, it is possible for the counters to detect the trigger on different edges on SOURCE. Thus, one counter could see the trigger one SOURCE period after the other. If you want to allow the counters to see the changes in the signal at the same instance, you should use pad synchronization.

Examples of applications where this feature is useful are those in which two or more counters are armed by an external start trigger, or that use the same PFI line as a counter control signal. *Pad synchronization* is only useful if the counters involved are using one of the internal timebases. A counter is using maximum timebase as its source if the synchronous counting mode is enabled for that counter.

Figures 3-33 and 3-34 indicate how pad synchronization can be useful. These figures assume a 1.5 and a 1.75 SOURCE cycle delay between the PFI-38 input pin, and GATE(0) and GATE(1), respectively. These delay values are exaggerated and are used for illustrative purposes. In Figure 3-33, counter 0 sees the gate edge on PFI\_38 one source period before counter 1 does.

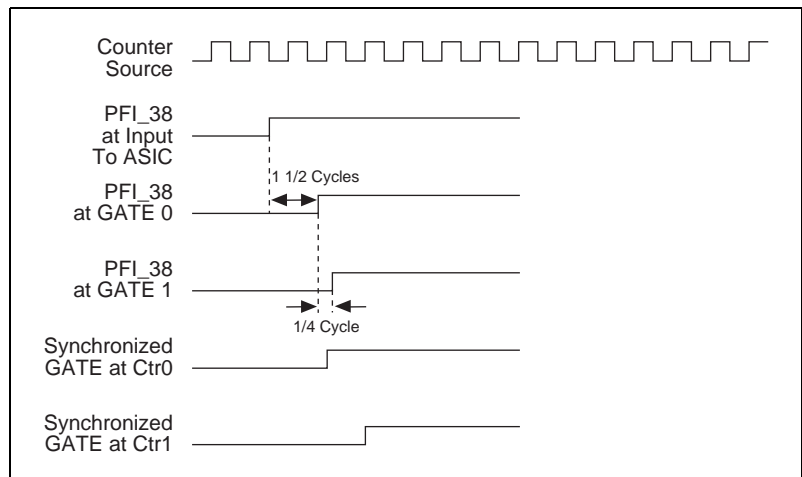

**Figure 3-33.** Counters 0 and 1 Using PFI\_38 as Gate without Pad Synchronization

In the Figure 3-34, both counters see the gate edge on PFI\_38 at the same time.

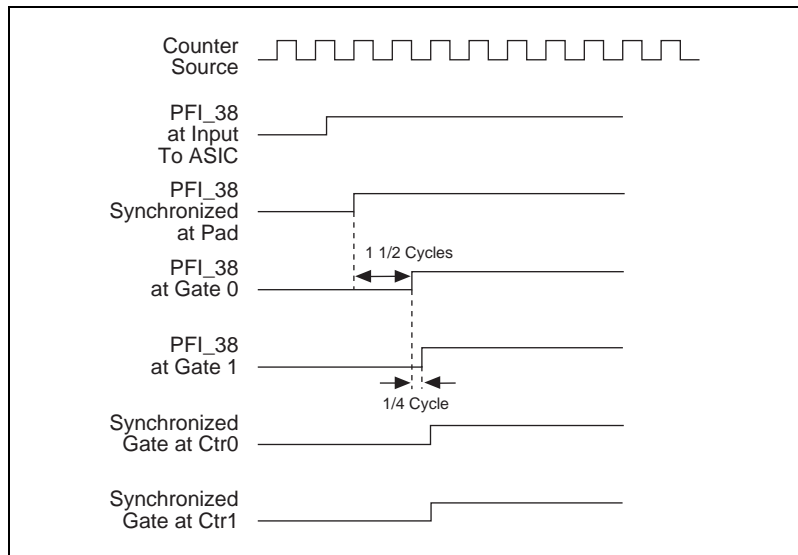

**Figure 3-34.** Counters 0 and 1 Using PFI\_38 as Gate with Pad Synchronization



**Note**

*An effect of this feature is that the signal is offset by one clock cycle.*

## Synchronous Counting Mode

Synchronous counting mode is set on a per counter basis. When this mode is enabled, the counter selects the 80 MHz timebase as its SOURCE.

However, the counter only counts if enabled by the synchronous-counting circuit for that counter. This circuit samples the signal at the output of the SOURCE selector for that counter, as shown in Figure 3-36. The circuit then enables the counter to allow one count each time it detects a transition to the active state on the signal it is sampling.

For example, if you are using counter 0 for event counting in the synchronous counting mode and you are counting a signal connected to PFI\_39 on the I/O connector, the SOURCE of counter 0 is the 80 MHz timebase. Counting on counter 0 occurs only when enabled by the synchronous-counting circuit for counter 0. This circuit samples PFI\_39 at the output of the SOURCE selector and enables counting on counter 0 for one count each time it detects a transition to the active state on PFI\_39. Thus counter 0 increments by one.



Figures 3-35 and 3-36 show counter operation with and without the synchronous counting mode. When the synchronous counting mode is not used, the counter is continuously enabled to count.

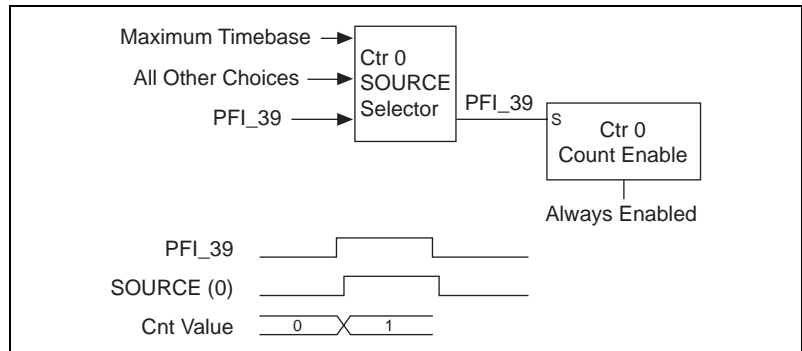

**Figure 3-35.** Without Synchronous Counting Mode

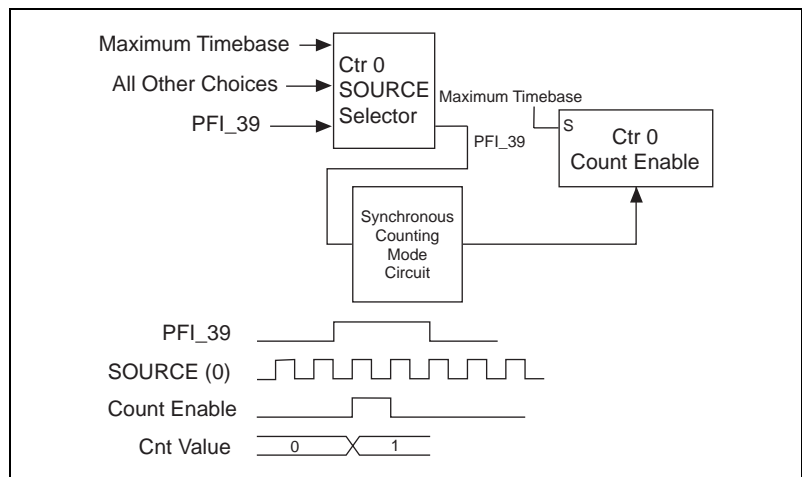

**Figure 3-36.** With Synchronous Counting Mode

## When Synchronous Counting Mode Should Be Used

Synchronous counting mode is recommended for buffered measurements where an external SOURCE is used and when the frequency of the external SOURCE is less than 20 MHz. It is particularly important to use this mode if you are using a low frequency or can expect zero SOURCE edges between successive GATE edges; otherwise you may receive incorrect data.

## When Synchronous Counting Should Not Be Used

Synchronous counting mode is not recommended for applications other than buffered measurements with an external SOURCE. Within the scope of recommended applications, synchronous counting mode should not be used if your frequency is greater than 20 MHz. Do not use synchronous counting mode if the external signal connected to the PFI line of the SOURCE of the counter to be used in the synchronous counting mode is to be used as the GATE for the other counter in a counter pair. Selecting `other_counter's_source` as the GATE chooses the selected SOURCE of the other counter as the GATE. The selected SOURCE in the synchronous counting mode is maximum timebase. See Table 4-2 and the [Flexible Period and Frequency Measurements](#) section in this chapter.

For example, if you are using PFI\_35 as the SOURCE of counter 1 for a buffered measurement and PFI\_35 as the GATE of counter 0 by choosing `other_counter's_source` as the GATE for counter 0, you should not use the synchronous counting mode for counter 1. If you do choose the synchronous counting mode and select the GATE of counter 0 to be `other_counter's_source`, the GATE of counter 0 will be maximum timebase, not PFI\_35. Your other option is to wire the same signal to PFI\_35 and PFI\_38 on the I/O connector and use PFI\_38 as the GATE of counter 0. You could then use counter 1 in the synchronous counting mode.

When synchronous-counting mode is not enabled, the counter expects at least one source edge between two successive gate edges for buffered measurements; if this condition is not met, you will get incorrect results. The application most likely to be affected by this scenario is buffered periodic event counting—intervals in which no source edges occur may return an incorrect value. If you are unable to use the synchronous counting mode for buffered periodic event counting and cannot guarantee at least one source edge between successive gates edges, you should use buffered event counting and use software to calculate the count in each interval.

## Transfer Rates

---

The maximum sustainable transfer rate a 6602 device can achieve for a buffered acquisition depends on the *minimum* available bus bandwidth and is based on your computer system, the number of other devices generating bus cycles, and your application software. The maximum sustainable transfer rate is always lower than the peak transfer rate.

To achieve the highest possible rates, consider the following information:

- Your system bus should be as free as possible from unrelated activity. Minimize the number of other I/O cards active in the system.
- Direct-memory access (DMA) transfers are faster than interrupt-driven transfers. By default, the software uses DMA if available.
  - ◆ The PCI-6602 always supports DMA transfers.
  - ◆ The PXI-6602 supports DMA if inserted into a peripheral slot that allows bus arbitration (bus mastering). When using a slot that does not allow bus arbitration, use software to select interrupt-driven transfers.

---

# Signal Connections

This chapter describes how to make input and output signal connections to your 6602 device via the device I/O connector and RTSI connector.

The I/O connector for the 6602 device has 68 pins. You can connect the 6602 device to 68-pin accessories through an SH68-68-D1 shielded cable or an R6868 ribbon cable.

Two or more National Instruments boards can be connected together via the RTSI bus. You can make this connection through the RTSI cable, available from National Instruments.

## I/O Connector

---

The 6602 devices have a 68-pin I/O connector, shown in Figure 4-1. The 40 signals associated with the I/O connector are referred to as PFI<0..39>. You can use PFI lines differently under different application contexts. For instance, PFI\_28 acts as OUT(2), the output of counter 2, when used in the counter context, but acts as DIO\_28 when used in the DIO context.

You can individually configure each pin for different application contexts. Thus, if you wish to use more than one application at one time, you may do so by individually configuring each pin as required. Figure 4-1 indicates the functionality of each PFI line under the different application contexts. If you are using only one type of application, Figures 4-2 through 4-4 give the pinout and functionality of the PFI lines for counter, DIO, and motion encoder applications alone, respectively.

**Caution**

*Connections that exceed any of the maximum input or output ratings on the 6602 may damage your device and your computer. See Appendix A, [Specifications](#), for maximum ratings. This warning includes connecting any power signals to ground and vice versa. National Instruments is NOT liable for any damages resulting from any such signal connections.*

Motion Encoder Context	DIO Context	Counter Context	Signal Names	Signal Names	Counter Context	DIO Context	Motion Encoder Context
Channel_A (2)	DIO_31	SOURCE (2)	PFI_31	34 68	GND	DIO_30	Index/z (2)
			GND	33 67			
Channel_A (3)	DIO_28	OUT (2)	PFI_28	32 66	GND	DIO_29	Channel_B (2)
			PFI_27	31 65			
Channel_A (4)	DIO_27	SOURCE (3)	PFI_27	31 65	GND	DIO_26	Index/z (3)
			GND	30 64			
Channel_A (5)	DIO_24	OUT (3)	PFI_24	29 63	GND	DIO_25	Channel_B (3)
			PFI_23	28 62			
Channel_A (6)	DIO_23	SOURCE (4)	PFI_23	28 62	GND	DIO_22	Index/z (4)
			GND	27 61			
Channel_A (7)	DIO_20	OUT (4)	PFI_20	26 60	GND	DIO_21	Channel_B (4)
			PFI_19	25 59			
Channel_A (8)	DIO_19	SOURCE (5)	PFI_19	25 59	GND	DIO_18	Index/z (5)
			GND	24 58			
Channel_A (9)	DIO_16	OUT (5)	PFI_16	23 57	GND	DIO_17	Channel_B (5)
			PFI_15	22 56			
Channel_A (10)	DIO_15	SOURCE (6)	PFI_15	22 56	GND	DIO_13	Channel_B (6)
			PFI_14	21 55			
Index/z (6)	DIO_14	GATE (6)	PFI_14	21 55	GND	DIO_12	Channel_A (7)
			GND	20 54			
Channel_B (7)	DIO_9	UP_DOWN (7) or AUX_LINE (7)	PFI_9	17 51	GND	DIO_11	Channel_A (7)
			PFI_8	16 50			
Channel_B (8)	DIO_8	OUT (7)	PFI_8	16 50	GND	DIO_10	Index/z (7)
			PFI_7	15 49			
Channel_B (9)	DIO_7	OUT (7)	PFI_7	15 49	GND	DIO_6	Channel_B (8)
			GND	14 48			
Channel_B (10)	DIO_4	OUT (7)	PFI_4	13 47	GND	DIO_5	Channel_B (9)
			PFI_3	12 46			
Channel_B (11)	DIO_3	OUT (7)	PFI_3	12 46	GND	DIO_2	Channel_B (10)
			GND	11 45			
Channel_B (12)	DIO_0	OUT (7)	PFI_0	10 44	GND	DIO_1	Channel_B (11)
			PFI_32	9 43			
Index/z (1)	DIO_0	GATE (1)	PFI_32	9 43	GND	DIO_1	Channel_B (12)
			PFI_34	8 42			
Channel_A (1)		SOURCE (1)	PFI_35	7 41	GND	DIO_0	Channel_B (0)
Channel_B (1)		UP_DOWN (1) or AUX_LINE (1)	PFI_33	6 40			
Channel_B (2)		OUT (0)	PFI_36	5 39	GND	DIO_0	Channel_B (1)
Channel_B (3)		OUT (0)	PFI_36	5 39			
Channel_B (4)		OUT (0)	Reserved	4 38	Reserved	DIO_0	Channel_B (2)
Channel_B (5)		OUT (0)	Reserved	4 38			
Index/z (0)		GATE (0)	PFI_38	3 37	Reserved	DIO_0	Channel_B (3)
Channel_A (0)		SOURCE (0)	PFI_39	2 36			
Channel_A (1)		SOURCE (0)	+5V	1 35	RG	DIO_0	Channel_B (4)
Channel_A (2)		SOURCE (0)	+5V	1 35			

GND: Ground  
 RG: 1. Reserved if using an SH68-68-D1 shielded cable  
 2. Ground if using an R6868 ribbon cable  
 OUT(x): OUT of counter x. The same applies for SOURCE (x), GATE (x) and UP\_DOWN (x)

Figure 4-1. Comprehensive Description of PFI Line Functionality

Counter Context	Signal Names	Signal Names	Counter Context
SOURCE (2)	PFI_31	34 68	GND
	GND	33 67	PFI_30 GATE (2)
OUT (2)	PFI_28	32 66	PFI_29 UP_DOWN (2) or AUX_LINE (2)
SOURCE (3)	PFI_27	31 65	GND
	GND	30 64	PFI_26 GATE (3)
OUT (3)	PFI_24	29 63	PFI_25 UP_DOWN (3) or AUX_LINE (3)
SOURCE (4)	PFI_23	28 62	GND
	GND	27 61	PFI_22 GATE (4)
OUT (4)	PFI_20	26 60	PFI_21 UP_DOWN (4) or AUX_LINE (4)
SOURCE (5)	PFI_19	25 59	GND
	GND	24 58	PFI_18 GATE (5)
OUT (5)	PFI_16	23 57	PFI_17 UP_DOWN (5) or AUX_LINE (5)
SOURCE (6)	PFI_15	22 56	RG
	GATE (6)	PFI_14	21 55
GND		20 54	PFI_13 UP_DOWN (6) or AUX_LINE (6)
UP_DOWN (7) or AUX_LINE (7)	PFI_9	19 53	PFI_12 OUT (6)
		18 52	PFI_11 SOURCE (7)
OUT (7)	PFI_8	17 51	PFI_10 GATE (7)
	PFI_7	16 50	GND
GND	PFI_4	15 49	GND
		14 48	PFI_6
PFI_3	PFI_3	13 47	PFI_5
		12 46	GND
GND	PFI_0	11 45	PFI_2
		10 44	PFI_1
OUT (1)	PFI_32	9 43	RG
GATE (1)	PFI_34	8 42	GND
SOURCE (1)	PFI_35	7 41	GND
UP_DOWN (1) or AUX_LINE (1)	PFI_33	6 40	PFI_37 UP_DOWN (0) or AUX_LINE (0)
		5 39	GND
OUT (0)	PFI_36	4 38	Reserved
GATE (0)	PFI_38	3 37	Reserved
		2 36	GND
SOURCE (0)	PFI_39	1 35	RG
	+5V		

GND: Ground  
RG: 1. Reserved if using an SH68-68-D1 shielded cable  
2. Ground if using an R6868 ribbon cable  
OUT(x): OUT of counter x. The same applies for SOURCE (x), GATE (x) and UP\_DOWN (x)

Figure 4-2. Description of PFI Lines for Counter Applications

DIO Context	Signal Names	Signal Names	DIO Context
DIO_31	PFL_31	34 68	GND
	GND	33 67	PFL_30 DIO_30
DIO_28	PFL_28	32 66	PFL_29 DIO_29
DIO_27	PFL_27	31 65	GND
	GND	30 64	PFL_26 DIO_26
DIO_24	PFL_24	29 63	PFL_25 DIO_25
DIO_23	PFL_23	28 62	GND
	GND	27 61	PFL_22 DIO_22
DIO_20	PFL_20	26 60	PFL_21 DIO_21
DIO_19	PFL_19	25 59	GND
	GND	24 58	PFL_18 DIO_18
DIO_16	PFL_16	23 57	PFL_17 DIO_17
DIO_15	PFL_15	22 56	RG
DIO_14	PFL_14	21 55	GND
	GND	20 54	PFL_13 DIO_13
	RG	19 53	PFL_12 DIO_12
	GND	18 52	PFL_11 DIO_11
DIO_9	PFL_9	17 51	PFL_10 DIO_10
DIO_8	PFL_8	16 50	GND
DIO_7	PFL_7	15 49	GND
	GND	14 48	PFL_6 DIO_6
DIO_4	PFL_4	13 47	PFL_5 DIO_5
DIO_3	PFL_3	12 46	GND
	GND	11 45	PFL_2 DIO_2
DIO_0	PFL_0	10 44	PFL_1 DIO_1
	PFL_32	9 43	RG
	PFL_34	8 42	GND
	PFL_35	7 41	GND
	PFL_33	6 40	PFL_37
	PFL_36	5 39	GND
	Reserved	4 38	Reserved
	PFL_38	3 37	Reserved
	PFL_39	2 36	GND
	+5V	1 35	RG

GND: Ground  
 RG: 1. Reserved if using an SH68-68-D1 shielded cable  
 2. Ground if using an R6868 ribbon cable

Figure 4-3. Description of PFI Lines for DIO Applications

Motion Encoder Context	Signal Names		Signal Names	Motion Encoder Context
Channel_A (2)	PFL_31	34	68	GND
	GND	33	67	PFL_30
Channel_A (3)	PFL_28	32	66	PFL_29
	PFL_27	31	65	GND
Channel_A (4)	GND	30	64	PFL_26
	PFL_24	29	63	PFL_25
Channel_A (5)	PFL_23	28	62	GND
	GND	27	61	PFL_22
Channel_A (6)	PFL_20	26	60	PFL_21
	PFL_19	25	59	GND
Index/Z (6)	GND	24	58	PFL_18
	PFL_16	23	57	PFL_17
Channel_B (7)	PFL_15	22	56	RG
	PFL_14	21	55	GND
Channel_A (1)	GND	20	54	PFL_13
	RG	19	53	PFL_12
Channel_B (1)	GND	18	52	PFL_11
	PFL_9	17	51	PFL_10
Index/Z (1)	PFL_8	16	50	GND
	PFL_7	15	49	GND
Channel_A (0)	GND	14	48	PFL_6
	PFL_4	13	47	PFL_5
Channel_B (0)	PFL_3	12	46	GND
	GND	11	45	PFL_2
Reserved	PFL_0	10	44	PFL_1
	PFL_32	9	43	RG
Index/Z (0)	PFL_34	8	42	GND
	PFL_35	7	41	GND
Channel_A (0)	PFL_33	6	40	PFL_37
	PFL_36	5	39	GND
Channel_A (0)	Reserved	4	38	Reserved
	PFL_38	3	37	Reserved
	PFL_39	2	36	GND
	+5V	1	35	RG

GND: Ground  
 RG: 1. Reserved if using an SH68-68-D1 shielded cable  
 2. Ground if using an R6868 ribbon cable

Figure 4-4. Description of PFI Lines for Motion Encoder Applications



## Output on Counter Pins

PFI <0..7> are used for DIO only. PFI <32..39> are used for counters and motion encoders only. You can use PFI <8..24> as either of the three choices. When used as an output, you can individually configure each PFI line as a DIO line or a counter line (you need not distinguish between counter/encoder or DIO applications when you use a PFI line as an input).

Furthermore, the PFI lines associated with gates and sources can be used as outputs associated with the counter. When used as such, these PFI lines drive the selected GATE or SOURCE associated with these lines. For example, if PFI\_39 is configured as an output, it will drive the selected SOURCE of counter 0. Table 4-1 summarizes what you can drive onto the different PFI lines when they are used as outputs.

**Table 4-1.** Signals That Can Be Driven onto the PFI Lines

PFI Line	Possible Signals
PFI_0	DIO_0
PFI_1	DIO_1
PFI_2	DIO_2
PFI_3	DIO_3
PFI_4	DIO_4
PFI_5	DIO_5
PFI_6	DIO_6
PFI_7	DIO_7
PFI_8	DIO_8 or OUT of counter 7
PFI_9	DIO_9
PFI_10	DIO_10 or GATE of counter 7
PFI_11	DIO_11 or SOURCE of counter 7
PFI_12	DIO_12 or OUT of counter 6
PFI_13	DIO_13

**Table 4-1.** Signals That Can Be Driven onto the PFI Lines (Continued)

<b>PFI Line</b>	<b>Possible Signals</b>
PFI_14	DIO_14 or GATE of counter 6
PFI_15	DIO_15 or SOURCE of counter 6
PFI_16	DIO_16 or OUT of counter 5
PFI_17	DIO_17
PFI_18	DIO_18 or GATE of counter 5
PFI_19	DIO_19 or SOURCE of counter 5
PFI_20	DIO_20 or OUT of counter 4
PFI_21	DIO_21
PFI_22	DIO_22 or GATE of counter 4
PFI_23	DIO_23 or SOURCE of counter 4
PFI_24	DIO_24 or OUT of counter 3
PFI_25	DIO_25
PFI_26	DIO_26 or GATE of counter 3
PFI_27	DIO_27 or SOURCE of counter 3
PFI_28	DIO_28 or OUT of counter 2
PFI_29	DIO_29
PFI_30	DIO_30 or GATE of counter 2
PFI_31	DIO_31 or SOURCE of counter 2
PFI_32	OUT of counter 1
PFI_33	Input only
PFI_34	GATE of counter 1
PFI_35	SOURCE of counter 1
PFI_36	OUT of counter 1
PFI_37	Input only

**Table 4-1.** Signals That Can Be Driven onto the PFI Lines (Continued)

PFI Line	Possible Signals
PFI_38	GATE of counter 0
PFI_39	SOURCE of counter 0



**Note**

*Output frequency on any of the pins should not exceed 40 MHz. The maximum frequency you can drive at the I/O connector is affected by the capacitive load presented by your cable. You can achieve 40 MHz output with a National Instruments 1m SH-68-68-D1 shielded cable (capacitive load = 80 pF). At larger loads, your maximum output frequency may be lower. You can output a pulse train with a frequency up to 20 MHz with a 10 m SH-68-68-D1 cable.*

## Counter Input Selections

Figure 4-5 explains the notation used in Table 4-2.

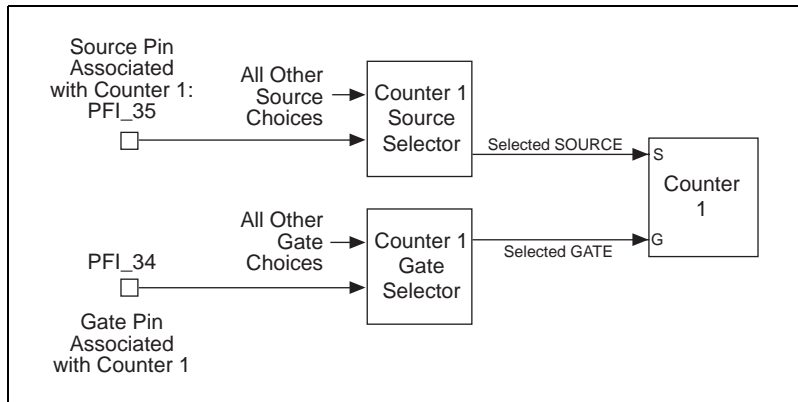

**Figure 4-5.** Counter Input

In Table 4-2, SOURCE means the actual source input of the counter. Do not confuse SOURCE with the PFI line associated with the source. For example, in the case of counter 1, SOURCE(1) is not necessarily the same as PFI(35). Selected SOURCE and SOURCE represent equivalent terms; they refer to the source input at the counter. The word *selected* is added in some instances for emphasis only. You have choices for what signals you can select as your counter’s SOURCE, GATE, AUX\_LINE, and UP\_DOWN, see Table 4-2.

**Table 4-2.** Possible Selections for Counter Input

Counter Input	Possible Selections
SOURCE	<p>The possible selections for SOURCE for each counter are as follows:</p> <p>PFI 11, PFI 15, PFI 19, PFI 23, PFI 27, PFI 31, PFI 35, PFI 39</p> <p>RTSI_0, RTSI_1, RTSI_2, RTSI_3, RTSI_4, RTSI_5, RTSI_6</p> <p>80 MHz internal timebase, 20 MHz internal timebase, 100 kHz internal timebase</p> <p>Selected GATE<sup>a</sup> of the other counter in the counter pair<sup>b</sup></p> <ul style="list-style-type: none"> <li>For counter 0: selected GATE of counter 1</li> <li>For counter 1: selected GATE of counter 0</li> <li>For counter 2: selected GATE of counter 3</li> <li>For counter 3: selected GATE of counter 2</li> <li>For counter 4: selected GATE of counter 5</li> <li>For counter 5: selected GATE of counter 4</li> <li>For counter 6: selected GATE of counter 7</li> <li>For counter 7: selected GATE of counter 6</li> </ul> <p>TC<sup>c</sup> of other counter in the counter pair<sup>b</sup></p> <ul style="list-style-type: none"> <li>For counter 0: TC of counter 1</li> <li>For counter 1: TC of counter 0</li> <li>For counter 2: TC of counter 3</li> <li>For counter 3: TC of counter 2</li> <li>For counter 4: TC of counter 5</li> <li>For counter 5: TC of counter 4</li> <li>For counter 6: TC of counter 7</li> <li>For counter 7: TC of counter 6</li> </ul>
GATE	<p>The possible selections for GATE for each counter are as follows:</p> <p>PFI 10, PFI 14, PFI 18, PFI 22, PFI 26, PFI 30, PFI 34, PFI 38</p> <p>RTSI_0, RTSI_1, RTSI_2, RTSI_3, RTSI_4, RTSI_5, RTSI_6</p> <p>Signal on PFI pin<sup>d</sup> (from I/O connector) that is associated with the source of the same counter:</p> <ul style="list-style-type: none"> <li>For counter 0: PFI 39</li> <li>For counter 1: PFI 35</li> <li>For counter 2: PFI 31</li> <li>For counter 3: PFI 27</li> <li>For counter 4: PFI 23</li> <li>For counter 5: PFI 19</li> <li>For counter 6: PFI 15</li> <li>For counter 7: PFI 11</li> </ul>

**Table 4-2.** Possible Selections for Counter Input (Continued)

Counter Input	Possible Selections
GATE	<p>Low</p> <p>OUT of other counter in counter pair<sup>b</sup></p> <ul style="list-style-type: none"> <li>For counter 0: OUT of counter 1</li> <li>For counter 1: OUT of counter 0</li> <li>For counter 2: OUT of counter 3</li> <li>For counter 3: OUT of counter 2</li> <li>For counter 4: OUT of counter 5</li> <li>For counter 5: OUT of counter 4</li> <li>For counter 6: OUT of counter 7</li> <li>For counter 7: OUT of counter 6</li> </ul> <p>Selected SOURCE<sup>a</sup> of the other counter in counter pair<sup>b</sup></p> <ul style="list-style-type: none"> <li>For counter 0: selected SOURCE of counter 1</li> <li>For counter 1: selected SOURCE of counter 0</li> <li>For counter 2: selected SOURCE of counter 3</li> <li>For counter 3: selected SOURCE of counter 2</li> <li>For counter 4: selected SOURCE of counter 5</li> <li>For counter 5: selected SOURCE of counter 4</li> <li>For counter 6: selected SOURCE of counter 7</li> <li>For counter 7: selected SOURCE of counter 6</li> </ul>
AUX_LINE	<p>The possible selections for AUX_LINE for each counter are as follows:</p> <p>PFI 9, PFI 13, PFI 17, PFI 21, PFI 25, PFI 29, PFI 33, PFI 37</p> <p>RTSI_0, RTSI_1, RTSI_2, RTSI_3, RTSI_4, RTSI_5, RTSI_6</p> <p>Signal on PFI pin<sup>d</sup> (from I/O connector) that is associated with the source of the same counter:</p> <ul style="list-style-type: none"> <li>For counter 0: PFI 39</li> <li>For counter 1: PFI 35</li> <li>For counter 2: PFI 31</li> <li>For counter 3: PFI 27</li> <li>For counter 4: PFI 23</li> <li>For counter 5: PFI 19</li> <li>For counter 6: PFI 15</li> <li>For counter 7: PFI 11</li> </ul> <p>OUT of other counter in counter pair<sup>b</sup></p> <ul style="list-style-type: none"> <li>For counter 0: OUT of counter 1</li> <li>For counter 1: OUT of counter 0</li> <li>For counter 2: OUT of counter 3</li> <li>For counter 3: OUT of counter 2</li> <li>For counter 4: OUT of counter 5</li> <li>For counter 5: OUT of counter 4</li> <li>For counter 6: OUT of counter 7</li> <li>For counter 7: OUT of counter 6</li> </ul>

**Table 4-2.** Possible Selections for Counter Input (Continued)

Counter Input	Possible Selections
AUX_LINE	Selected SOURCE <sup>c</sup> of the other counter in counter pair <sup>b</sup> For counter 0: selected SOURCE of counter 1 For counter 1: selected SOURCE of counter 0 For counter 2: selected SOURCE of counter 3 For counter 3: selected SOURCE of counter 2 For counter 4: selected SOURCE of counter 5 For counter 5: selected SOURCE of counter 4 For counter 6: selected SOURCE of counter 7 For counter 7: selected SOURCE of counter 6
UP_DOWN	The possible selections for UP_DOWN for each counter are as follows: For counter 0: PFI 37, or software up, or software down For counter 1: PFI 33, or software up, or software down For counter 2: PFI 29, or software up, or software down For counter 3: PFI 25, or software up, or software down For counter 4: PFI 21, or software up, or software down For counter 5: PFI 17, or software up, or software down For counter 6: PFI 13, or software up, or software down For counter 7: PFI 9, or software up, or software down
<p>a. Selected GATE of other counter means the signal that has been chosen as GATE of the other counter in the counter pair. This may be different from the signal on the PFI line that corresponds to the gate of the other counter.</p> <p>b. The eight counters on a 6602 device are arranged in four counter pairs: counters 0 and 1, counters 2 and 3, counters 4 and 5, and counters 6 and 7.</p> <p>c. TC, which denotes <i>terminal count</i>, is a pulse that is generated each time a counter reaches zero from either direction.</p> <p>d. The PFI pin that is associated with the source of the same counter can be found from Table 4-2. For example, for counter 0, it is PFI_39. This signal, when used as GATE, should be different from SOURCE that is selected for the counter—SOURCE of the counter can be selected as shown in this table above. If this selection is chosen for GATE and filtering is enabled for the PFI line that corresponds to SOURCE of the counter, this filtered signal will be selected as the GATE. For example, if you (1) select GATE of counter 1 to be signal on PFI pin (from I/O connector) that is associated with the source of the same counter and (2) have enabled filtering on PFI_35, the GATE signal of counter 1 will be the filtered version of the signal on PFI_35.*</p> <p>e. Selected GATE of other counter means the signal that has been chosen as GATE of the other counter in the counter pair. This may be different from the signal on the PFI line that corresponds to the gate of the other counter.</p>	
<p>*See the <i>Flexible Period and Frequency Measurements</i> section in Chapter 3, <i>Device Overview</i>, for explanation of when this selection may be useful.</p>	

## Signal Characteristics

Following is a list of signal characteristics. Characteristics are for all signals, unless otherwise noted. For signal characteristics not given in this section, see Appendix A, *Specifications*.

- Drive current—After being enabled, all lines that can be configured for output sink at least 4 mA at 0.4 V, and source at least 4 mA at 2.4 V.
- Ground reference—All signals are referenced to the GND lines.
- Initial state—At power up, all PFI and RTSI lines begin at high impedance. Due to the circuitry inside the NI-TIO ASICs on a 6602 device, the voltage levels of PFI lines are pulled low. RTSI lines are pulled high.
- Polarity—All signals on the PFI lines are active high unless configured otherwise by software. A 1 or active level corresponds to a high voltage, and a 0 or inactive level corresponds to a low voltage.

## RTSI Bus Interface

The PCI-6602 and PXI-6602 each contain a RTSI bus interface.

### ◆ PCI-6602

The PCI-6602 contains a RTSI connector and an interface to the National Instruments RTSI bus. The RTSI bus has seven trigger lines and a system clock line. If a RTSI clock is not required, the RTSI clock line can be used as an eighth RTSI trigger line. All National Instruments AT and PCI boards that have RTSI bus connectors can be cabled together inside a computer to share these signals.

### ◆ PXI-6602

The PXI-6602 uses pins on the PXI J2 connector to connect the RTSI bus to the PXI trigger bus as defined in the *PXI Specification*, revision 1.0. All National Instruments PXI boards that have a connection to these pins can be connected together by software. This feature is available only when the PXI-6602 is used in a PXI-compatible chassis. It is not supported in CompactPCI chassis.

## Board and RTSI Clocks

A 6602 device requires a frequency timebase for its operation. This frequency timebase must be 80 MHz and must come from the crystal oscillator on a 6602 device. For bandwidth reasons, the RTSI bus cannot carry an 80 MHz timebase. However, a 6602 device can drive its 20 MHz timebase onto the RTSI clock line for use by other boards that use a 20 MHz clock, and receive the same from another device to use as its 20 MHz timebase. By default, a 6602 device does not drive the RTSI bus clock line.

- ◆ PXI-6602—The PXI-6602 uses PXI trigger line 7 as its RTSI clock line.

## RTSI Triggers

The seven trigger lines on the RTSI bus allow connection between devices sharing the RTSI bus. The remaining RTSI line, RTSI Clock, can be used as either a clock line or an eighth RTSI trigger. You can drive and receive signals from the RTSI bus. Table 4-3 shows what can be driven onto the RTSI bus.

**Table 4-3.** Signals That Can Be Driven onto the RTSI Bus

RTSI Signal	Possible Solutions for Output
RTSI_Trigger<0..6>	OUT of any of the counters (counter 0 through counter 7)
RTSI_Trigger 7	OUT of any of the counters, or 20 MHz timebase

When used as inputs, RTSI\_Trigger <0..6> can be used as the SOURCE or GATE of any of the counters.

- ◆ PXI-6602—RTSI trigger lines 0 through 5 correspond to PXI trigger bus lines 0 through 5. RTSI trigger 6 corresponds to the PXI start trigger.

## Pull-Up and Pull-Down Connections

The PFI lines are weakly pulled down within the NI-TIO ASIC. The pull-down characteristics are indicated with the specifications in Appendix A, *Specifications*. If the PFI lines must be pulled up or if stronger pull-down characteristics are required, you must make such connections external to the 6602 device. Such connections will affect the drive strength of the 6602 devices when the lines thus pulled up or down are used as outputs. The RTSI lines are weakly pulled high.



## Power Connections

---

The +5 V pin on the I/O connector supplies power from the computer power supply through a self-resetting fuse. The fuse resets automatically within a few seconds after removal of an overcurrent condition. The power pin is referenced to the GND pins and can supply power to external, digital circuitry. The power rating for the 6602 devices is +4.65 to +5.25 VDC at 1 A.



**Caution** *Do not connect the +5 V power pin directly to the GND pin, the RG pin, any pin configured for output on the 6602 device, or any voltage source or output pin on another device. Doing so can damage the device and the computer. National Instruments is NOT liable for damages resulting from such a connection.*

## Field Wiring and Termination

---

Transmission line effects, environmental noise, and crosstalk can lead to incorrect results if you do not take proper care when running signal wires to and from the device. Recommendations for how to minimize each problem are discussed below. Also, you may be able to use the debouncing filters available on each PFI line to avoid errors that these problems can cause. See the [Filters](#) section in Chapter 3, [Device Overview](#).



**Note** *Make sure your 6602 device and your peripheral device share a common ground reference. Connect one or more 6602 device GND lines to the GND reference of your peripheral device.*

## Transmission Line Effects

---

Transmission line effects can degrade the signal and cause measurement errors. Use twisted-pair wires to connect external signals to the device to improve impedance matching and signal integrity.

The 6602 device provides onboard series termination to reduce signal reflections when a 6602 device drives an output. If you still experience problems with reflections when the 6602 device drives the signal, use parallel AC termination at the destination. Recommended values for  $R_p$  and  $C_p$  are 68  $\Omega$  and 150 pF, respectively, with a National Instruments SH68-68-D1 cable.

If you experience problems with reflections when the 6602 device receives the signal, use series termination at the device that drives the signal. See Figure 4-6. The sum of  $R_s$  and the output impedance of your source should be about  $80\Omega$ . Typically, this condition results in a value of about  $50\Omega$  for  $R_s$ . If your source impedance is larger than  $80$  and you need to use series termination, you will need to use a voltage follower with low output impedance and connect  $R_s$  at the output of the voltage follower. Before using a voltage follower or series termination, try to eliminate measurement errors by using the filters inside the NI-TIO. See *Filters* in Chapter 3, *Device Overview*.

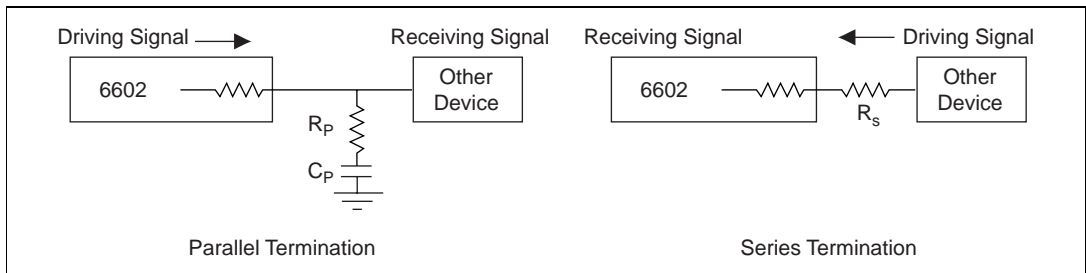

**Figure 4-6.** Parallel and Series Termination

## Noise

Take the following precautions to minimize noise pickup:

- Route signals to the device carefully. Keep cabling away from noise sources.
- Separate 6602 device signal lines from high-current or high-voltage lines. These lines are capable of inducing currents in or voltages on the 6602 device signal lines if they run in parallel paths at a close distance. To reduce the magnetic coupling between lines, separate them by a reasonable distance if they run in parallel, or run the lines at right angles to each other.
- Do not run signal lines through conduits that also contain power lines.
- Protect signal lines from magnetic fields cause by monitors, electric motors, welding equipment, breakers, transformers, or other devices by running them through special metal conduits.

The inputs on the NI-TIO ASICs on the 6602 devices have hysteresis that offers improved noise immunity.

# Crosstalk

Due to capacitance between the lines in a cable, a signal transition on one line may induce a smaller transition on another line. This phenomenon is referred to as crosstalk. Lines configured as input are most susceptible to crosstalk. Figure 4-7 shows an example of crosstalk.

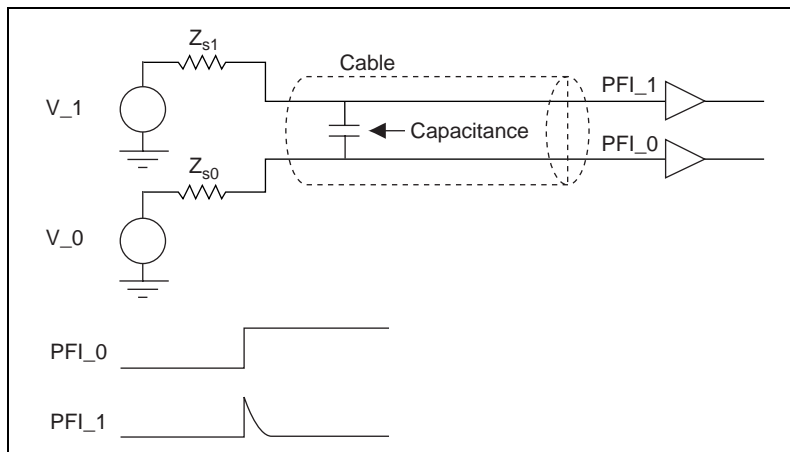

**Figure 4-7.** Crosstalk

PFI\_0 and PFI\_1 are configured as inputs. V\_0 drives PFI\_0 and V\_1 drives PFI\_1. When PFI\_0 (the offending line) transitions from one state to another, it induces a small transition in PFI\_1 (the victim line) also. The magnitude of the transition (or crosstalk) induced in PFI\_1 is proportional to the speed of the transition on PFI\_0, the length of the cable being used and the source impedance of V\_1 (the voltage that drives the victim line). Crosstalk is most likely to cause measurement errors when the victim line is at a low voltage. If this crosstalk is 0.5 V or greater, you may get errors in measurement.

You should not experience crosstalk if the source impedance of the voltage source driving the victim line is less than 100  $\Omega$ . If this source impedance is larger than 100  $\Omega$  and you see crosstalk problems, you should use NI-TIO filters (see [Filters](#) in Chapter 3, [Device Overview](#)) or a voltage follower with a low output impedance to drive the victim line.

## Inductive Effects

For high-speed signals, inductive effects can degrade signal integrity and cause ringing. To minimize inductive effects, you must minimize ground loops and allow a return path for currents. Twist your signal with a ground wire when you connect it to the 68-pin connector block you are using. Connect the signal wire to the PFI pin you are using and connect the ground wire to the adjacent GND line with which the PFI line is twisted. See Figure 4-8 and Table 4-4.

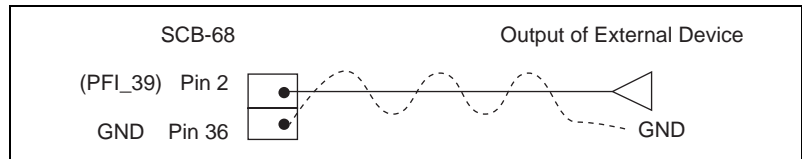

**Figure 4-8.** Wiring to Minimize Inductive Effects

The SH68-68-D1 cable is designed to help minimize inductive effects. Each signal line is twisted with a ground wire connected to a nearby pin. Each ground is shared by two signal lines. Table 4-4 lists the signals and the pin number of the ground on a 68-pin connector block with which each signal is twisted.

**Table 4-4.** Pin Number of Associated GND on 68-Pin Connector Block

PFI Number	Pin Number for GND
PFI_0	11
PFI_1	11
PFI_2	46
PFI_3	46
PFI_4	14
PFI_5	14
PFI_6	49
PFI_7	49
PFI_8	50
PFI_9	50

**Table 4-4.** Pin Number of Associated GND on 68-Pin Connector Block (Continued)

<b>PFI Number</b>	<b>Pin Number for GND</b>
PFI_10	18
PFI_11	18
PFI_12	20
PFI_13	20
PFI_14	55
PFI_15	55
PFI_16	24
PFI_17	24
PFI_18	59
PFI_19	59
PFI_20	27
PFI_21	27
PFI_22	62
PFI_23	62
PFI_24	30
PFI_25	30
PFI_26	65
PFI_27	65
PFI_28	33
PFI_29	33
PFI_30	68
PFI_31	68
PFI_32	42
PFI_33	39

**Table 4-4.** Pin Number of Associated GND on 68-Pin Connector Block (Continued)

<b>PFI Number</b>	<b>Pin Number for GND</b>
PFI_34	42
PFI_35	41
PFI_36	39
PFI_37	41
PFI_38	36
PFI_39	36

## Specifications

This appendix lists the specifications for the 6602 devices. These specifications are typical at 25° C unless otherwise noted.

### PCI /PXI-6602 Device

#### I/O Characteristics

(Apply to digital and counter/timer I/O)

Compatibility ..... TTL/CMOS

Power-on state..... Input (high-Z) with weak pull-downs  
Pull-down current: 10  $\mu$ A (min) to 200  $\mu$ A (max)

Hysteresis ..... 300 mV Schmitt triggers

#### Digital logic levels

Level	Min	Max
Input low voltage	-0.3 V	0.8 V
Input high voltage	2.0 V	Supply +0.3 V
Input low current ( $V_{in}=0$ V)	—	-10 $\mu$ A
Input high current ( $V_{in}=\text{Supply}$ )	—	200 $\mu$ A
Output low voltage ( $I_{out}=4$ mA)	—	0.4 V
Output high voltage ( $I_{out}=4$ mA)	2.4 V	—

## Digital I/O

Number of channels.....	32
Data transfers.....	Static
Handshaking.....	None

## Timing I/O

Number of channels.....	8 up/down counters
Resolution.....	32 bits
Maximum Count.....	4,294,967,295
Rollover times	
100 kHz timebase.....	11.93 hours
20 MHz timebase.....	214.74 s
80 MHz timebase.....	53.69 s
Pre-scalers.....	X8 or X2 prescaler for each counter
Base clocks available.....	100 kHz, 20 MHz, and 80 MHz
Base clock accuracy.....	50 ppm ( $\pm 0.005\%$ ) over temperature
Maximum source frequency <sup>1</sup>	
without prescaling.....	80 MHz
with prescaling.....	125 MHz
Minimum source pulse duration <sup>1</sup>	
without prescaling.....	5 ns in edge-detection mode
with prescaling.....	3.5 ns in edge-detection mode
Minimum gate pulse duration.....	5 ns in edge-detection mode
Data transfers.....	DMA, interrupts
DMA modes.....	Scatter-gather

---

<sup>1</sup> See Appendix B, *Timing Specifications*.



## RTSI (PCI-6602 Only)

Trigger lines ..... 7 (8 in the absence of RTSI clock)

Minimum pulse width for  
trigger and clock..... 50 ns

## PXI Trigger Bus (PXI-6602 Only)

Trigger lines ..... 6

Star trigger..... 1

## Bus Interface

All devices..... Master, slave

## Power

Device requirement ..... +5 VDC ( $\pm 5\%$ ), 0.5 A to 1.5 A  
(with 1 m shielded cable as load)  
varies with application, does not  
include I/O power supplied  
through I/O connector

Available at I/O connector ..... 4.65 to 5.25 VDC, 1 A

## Physical

### Dimensions

PCI-6602 ..... 17.5 by 9.9 cm  
(6.9 by 3.9 in.)

PXI-6602 ..... 16.0 by 10.0 cm  
(6.3 by 3.9 in.)

I/O connector..... 68-pin male, SCSI-II type

## Environment

Operating temperature .....0° to 50° C

Storage temperature .....-20° to 70° C

Relative humidity .....10% to 95% noncondensing

## Timing Specifications

This appendix provides timing specifications for the counters on your 6602 device.

### Counter Source Minimum Period and Minimum Pulse Width

Figure B-1 shows the minimum period and pulse width that you must use on signals used as the SOURCE of any of the counters. The signal that is used as a counter source must satisfy both minimum criteria. Thus, if the high phase of the source signal is  $T_{srcpw}$  ns, the low phase must be  $T_{srcper} - T_{srcpw}$  ns.

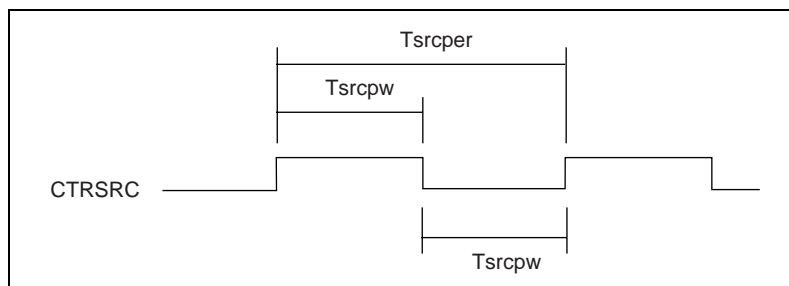

**Figure B-1.** Counter SOURCE Minimum Period and Minimum Pulse Width

**Table B-1.** Counter SOURCE Minimum Period and Minimum Pulse Width

Parameter	Minimum in nanoseconds	Description
$T_{srcpw}$ (without prescaling)	5	SOURCE minimum pulse width (without prescaling)
$T_{srcpw}$ (with prescaling)	3.5	SOURCE minimum pulse width (with prescaling)
$T_{srcper}$ (without prescaling)	12.5	SOURCE minimum period (without prescaling)
$T_{srcper}$ (with prescaling)	8	SOURCE minimum period (with prescaling)

As frequencies become higher, the cable introduces greater losses due to capacitance—the longer your cable, the larger the losses. The quality of the signal at the input of the ASIC depends on the length of cable you are using and on the source that is driving the signal. A weak source or a lossy cable may lower the maximum frequency you can count at. A source with a power rating of 13 dBm can drive a National Instruments 1 m SH-68-68-D1 shielded cable at (capacitive load = 80 pF) 125 MHz and present an acceptable signal to the 6602.

**Note**

If you are using the synchronous counting mode, the minimum period of signal being used as the source of the counter must be greater than twice the period of the maximum timebase.

## Counter Gate Minimum Pulse Width

Figure B-2 shows the minimum pulse width that you must use on signals used as the gate of any of the counters.

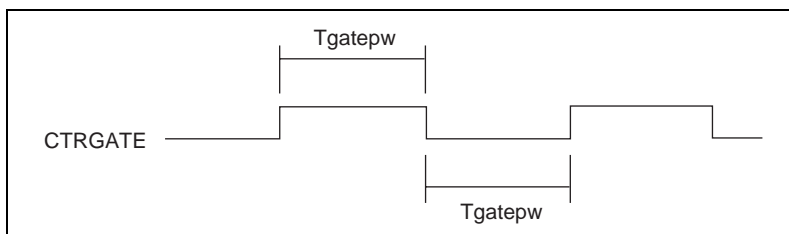

**Figure B-2.** Counter GATE Minimum Pulse Width

**Table B-2.** Counter GATE Minimum Pulse Width

Parameter	Minimum	Description
Tgatepw	5 ns	GATE minimum pulse width

**Note**

*For buffered measurements, the minimum period required for the signal being used as the gate of the counter is determined by how fast your system can transfer data from your 6602 device to your computer's memory.*

## Counter Source to Counter Out Delay

Figure B-3 shows the delay between the active edge of the counter source signal and the active edge of the counter output signal. In Figure B-3, both counter source and counter out are active high. The values represent pin-to-pin delay at the 6602 I/O connector. The corresponding delay values at a connector block will be larger due to cable delays. If you are using an external source connected to PFI\_39 for counter 0 and looking at the counter 0 output on PFI\_36, these values represent the delay between a rising edge of PFI\_39 and a rising edge on PFI\_36 when the counter output toggles from low to a high state. If you use the pulse output mode, you will see the TC pulse on PFI\_36. The TC pulse occurs one source period before the output toggles under the toggle output mode (see [Simple Pulse and Pulse-Train Generation](#) in Chapter 3, [Device Overview](#)).

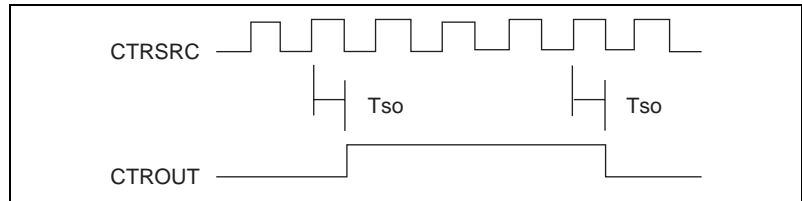

**Figure B-3.** Counter Source to Counter Out Timing

**Table B-3.** Counter Source to Counter Out Timing

Parameter	Typical	Maximum	Description
$T_{so}$	16 ns	26 ns	External source to external out delay

When using the toggle output mode, the maximum output frequency is one-quarter of the maximum timebase. When using the pulsed mode, the maximum frequency is one-half of the maximum timebase.



# Block Diagram

Figure C-1 shows the block diagram for the 6602 devices.

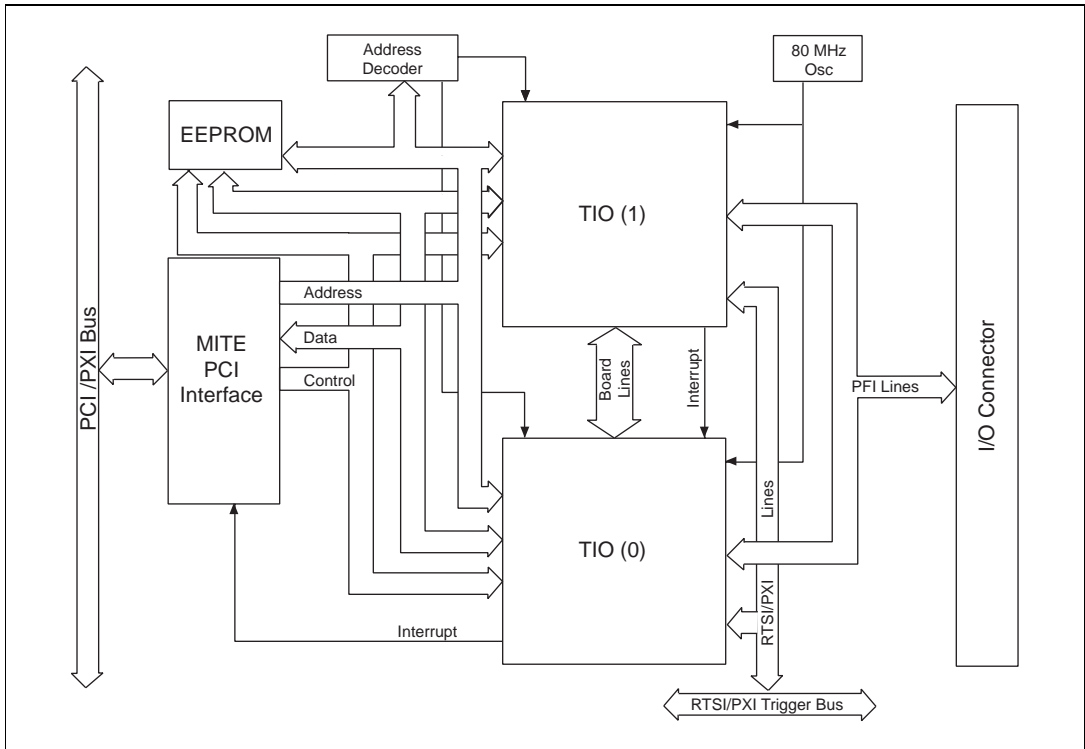

**Figure C-1.** PCI/PXI-6602 Block Diagram

---

# Customer Communication

For your convenience, this appendix contains forms to help you gather the information necessary to help us solve your technical problems and a form you can use to comment on the product documentation. When you contact us, we need the information on the Technical Support Form and the configuration form, if your manual contains one, about your system configuration to answer your questions as quickly as possible.

National Instruments has technical assistance through electronic, fax, and telephone systems to quickly provide the information you need. Our electronic services include a bulletin board service, an FTP site, a fax-on-demand system, and e-mail support. If you have a hardware or software problem, first try the electronic support systems. If the information available on these systems does not answer your questions, we offer fax and telephone support through our technical support centers, which are staffed by applications engineers.

## Electronic Services

### Bulletin Board Support

National Instruments has BBS and FTP sites dedicated for 24-hour support with a collection of files and documents to answer most common customer questions. From these sites, you can also download the latest instrument drivers, updates, and example programs. For recorded instructions on how to use the bulletin board and FTP services and for BBS automated information, call 512 795 6990. You can access these services at:

United States: 512 794 5422

Up to 14,400 baud, 8 data bits, 1 stop bit, no parity

United Kingdom: 01635 551422

Up to 9,600 baud, 8 data bits, 1 stop bit, no parity

France: 01 48 65 15 59

Up to 9,600 baud, 8 data bits, 1 stop bit, no parity

### FTP Support

To access our FTP site, log on to our Internet host, `ftp.natinst.com`, as anonymous and use your Internet address, such as `joesmith@anywhere.com`, as your password. The support files and documents are located in the `/support` directories.

## Fax-on-Demand Support

Fax-on-Demand is a 24-hour information retrieval system containing a library of documents on a wide range of technical information. You can access Fax-on-Demand from a touch-tone telephone at 512 418 1111.

## E-Mail Support (Currently USA Only)

You can submit technical support questions to the applications engineering team through e-mail at the Internet address listed below. Remember to include your name, address, and phone number so we can contact you with solutions and suggestions.

support@natinst.com

## Telephone and Fax Support

National Instruments has branch offices all over the world. Use the list below to find the technical support number for your country. If there is no National Instruments office in your country, contact the source from which you purchased your software to obtain support.

<b>Country</b>	<b>Telephone</b>	<b>Fax</b>
Australia	03 9879 5166	03 9879 6277
Austria	0662 45 79 90 0	0662 45 79 90 19
Belgium	02 757 00 20	02 757 03 11
Brazil	011 288 3336	011 288 8528
Canada (Ontario)	905 785 0085	905 785 0086
Canada (Québec)	514 694 8521	514 694 4399
Denmark	45 76 26 00	45 76 26 02
Finland	09 725 725 11	09 725 725 55
France	01 48 14 24 24	01 48 14 24 14
Germany	089 741 31 30	089 714 60 35
Hong Kong	2645 3186	2686 8505
Israel	03 6120092	03 6120095
Italy	02 413091	02 41309215
Japan	03 5472 2970	03 5472 2977
Korea	02 596 7456	02 596 7455
Mexico	5 520 2635	5 520 3282
Netherlands	0348 433466	0348 430673
Norway	32 84 84 00	32 84 86 00
Singapore	2265886	2265887
Spain	91 640 0085	91 640 0533
Sweden	08 730 49 70	08 730 43 70
Switzerland	056 200 51 51	056 200 51 55
Taiwan	02 377 1200	02 737 4644
United Kingdom	01635 523545	01635 523154
United States	512 795 8248	512 794 5678



# Technical Support Form

Photocopy this form and update it each time you make changes to your software or hardware, and use the completed copy of this form as a reference for your current configuration. Completing this form accurately before contacting National Instruments for technical support helps our applications engineers answer your questions more efficiently.

If you are using any National Instruments hardware or software products related to this problem, include the configuration forms from their user manuals. Include additional pages if necessary.

Name \_\_\_\_\_

Company \_\_\_\_\_

Address \_\_\_\_\_

\_\_\_\_\_

Fax ( \_\_\_\_ ) \_\_\_\_\_ Phone ( \_\_\_\_ ) \_\_\_\_\_

Computer brand \_\_\_\_\_ Model \_\_\_\_\_ Processor \_\_\_\_\_

Operating system (include version number) \_\_\_\_\_

Clock speed \_\_\_\_\_ MHz RAM \_\_\_\_\_ MB Display adapter \_\_\_\_\_

Mouse \_\_\_yes \_\_\_no Other adapters installed \_\_\_\_\_

Hard disk capacity \_\_\_\_\_ MB Brand \_\_\_\_\_

Instruments used \_\_\_\_\_

\_\_\_\_\_

National Instruments hardware product model \_\_\_\_\_ Revision \_\_\_\_\_

National Instruments software product \_\_\_\_\_ Version \_\_\_\_\_

The problem is: \_\_\_\_\_

\_\_\_\_\_

\_\_\_\_\_

\_\_\_\_\_

List any error messages: \_\_\_\_\_

\_\_\_\_\_

\_\_\_\_\_

The following steps reproduce the problem: \_\_\_\_\_

\_\_\_\_\_

\_\_\_\_\_

\_\_\_\_\_

\_\_\_\_\_

# PCI/PXI-6602 Hardware and Software Configuration Form

Record the settings and revisions of your hardware and software on the line to the right of each item. Complete a new copy of this form each time you revise your software or hardware configuration, and use this form as a reference for your current configuration. Completing this form accurately before contacting National Instruments for technical support helps our applications engineers answer your questions more efficiently.

## National Instruments Products

Hardware revision \_\_\_\_\_

Interrupt level of hardware \_\_\_\_\_

Memory range of hardware \_\_\_\_\_

Programming choice \_\_\_\_\_

National Instruments software \_\_\_\_\_

Other boards in system \_\_\_\_\_

Base I/O address/memory range of other boards \_\_\_\_\_

DMA channels of other boards (AT/PC bus) \_\_\_\_\_

Interrupt level of other boards \_\_\_\_\_

## Other Products

Computer make and model \_\_\_\_\_

Microprocessor \_\_\_\_\_

Clock frequency or speed \_\_\_\_\_

Type of video board installed \_\_\_\_\_

Operating system version \_\_\_\_\_

Programming language \_\_\_\_\_

Programming language version \_\_\_\_\_

Other boards in system \_\_\_\_\_

Base I/O address/memory range of other boards \_\_\_\_\_

DMA channels of other boards \_\_\_\_\_

Interrupt level of other boards \_\_\_\_\_

# Documentation Comment Form

National Instruments encourages you to comment on the documentation supplied with our products. This information helps us provide quality products to meet your needs.

**Title:** *PCI/PXI-6602 User Manual*

**Edition Date:** October 1998

**Part Number:** 322137A-01

Please comment on the completeness, clarity, and organization of the manual.

---

---

---

---

---

---

---

---

If you find errors in the manual, please record the page numbers and describe the errors.

---

---

---

---

---

---

---

---

Thank you for your help.

Name \_\_\_\_\_

Title \_\_\_\_\_

Company \_\_\_\_\_

Address \_\_\_\_\_

E-Mail Address \_\_\_\_\_

Phone ( \_\_\_\_ ) \_\_\_\_\_ Fax ( \_\_\_\_ ) \_\_\_\_\_

**Mail to:** Technical Publications  
National Instruments Corporation  
6504 Bridge Point Parkway  
Austin, Texas 78730-5039

**Fax to:** Technical Publications  
National Instruments Corporation  
512 794 5678

# Glossary

Prefix	Meaning	Value
c-	centi-	$10^{-2}$
m-	milli-	$10^{-3}$
$\mu$ -	micro-	$10^{-6}$
n-	nano-	$10^{-9}$
k-	kilo-	$10^3$
M-	mega-	$10^6$

## Symbols

°	degree
–	negative of, or minus
/	per
%	percent
±	plus or minus
+	positive of, or plus

## A

A	amperes
ANSI	American National Standards Institute
API	application programming interface
arm	to enable a counter to start an operation. If the application requires a trigger, an armed counter waits for the trigger to begin the operation.
ASIC	application specific integrated circuit

asynchronous a property of an event that occurs at an arbitrary time, without synchronization to a reference clock

## **B**

b bit—one binary digit, either 0 or 1

B byte—eight related bits of data, an eight-bit binary number. Also used to denote the amount of memory required to store one byte of data.

base address a memory address that serves as the starting address for programmable registers. All other addresses are located by adding to the base address.

buffer a block of memory used to store measurement results

buffered a type of measurement in which multiple measurements are made consecutively and measurement results are stored in a buffer

bus the group of conductors that interconnect individual circuitry in a computer. Typically, a bus is the expansion vehicle to which I/O or other devices are connected. Examples of PC buses are the AT, EISA, and PCI bus.

## **C**

C Celsius

clock hardware component that provides timing for various device operations

cm centimeters

CMOS complementary metal-oxide semiconductor

CompactPCI an electrical superset of the PCI bus architecture with a mechanical form factor suited for industrial applications

crosstalk an unwanted signal on one channel due to activity on a different channel

current drive capability the amount of current a digital or analog output channel is capable of sourcing or sinking while still operating within voltage range specifications

current sinking the ability of a DAQ board to dissipate current for analog or digital output signals

current sourcing      the ability of a DAQ board to supply current for analog or digital output signals

## D

DAQ      data acquisition—(1) collecting and measuring electrical signals from sensors, transducers, and test probes or fixtures and inputting them to a computer for processing; (2) collecting and measuring the same kinds of electrical signals with A/D and/or DIO boards plugged into a computer, and possibly generating control signals with D/A and/or DIO boards in the same computer

DAQ-STC      a custom ASIC developed by National Instruments that provides timing information and general-purpose counter/timers on National Instruments E Series boards

DC      direct current

decode      used in the context of motion encoders. The two channels of a motion encoder indicate information about movement and direction of movement of an external device. Decoding refers to extracting this information from the signals on these channels.

device      a plug-in data acquisition board, card, or pad that can contain multiple channels and conversion devices. Plug-in boards, PCMCIA cards, and DAQ devices that connect to your computer parallel port, are all examples of DAQ devices.

DIO      digital input/output

DLL      dynamic link library—a software module in Microsoft Windows containing executable code and data that can be called or used by Windows applications or other DLLs. Functions and data in a DLL are loaded and linked at run time when they are referenced by a Windows application or other DLLs.

DMA      direct memory access—a method by which data can be transferred to/from computer memory from/to a device or memory on the bus while the processor does something else. DMA is the fastest method of transferring data to/from computer memory.

driver software that controls a specific hardware device such as a DAQ board

## **E**

EEPROM electrically erasable programmable read-only memory—ROM that can be erased with an electrical signal and reprogrammed

EISA extended industry standard architecture

encode used in the context of motion encoders. Motion encoders provide information about movement and direction of movement of an external device. The process of producing the pulses that contain this information is called encoding.

ETS equivalent time sampling

## **F**

FSK frequency shift keying

## **G**

GATE the signal that controls the operation of a counter. This signal may start or stop the operation of a counter, reload the counter, or save the results of a counter.

glitch a brief, unwanted change, or disturbance, in a signal level

GND ground

## **H**

hardware the physical components of a computer system, such as the circuit boards, plug-in boards, chassis, enclosures, peripherals, cables, and so on

HW hardware

HW Save Register a register inside the NI-TIO ASIC that stores the result of a measurement

Hz hertz—a unit of frequency. One hertz corresponds to one cycle or event per second

**I**

in.	inches
interrupt	a computer signal indicating that the CPU should suspend its current task to service a designated activity
interrupt level	the relative priority at which a device can interrupt
I/O	input/output—the transfer of data to/from a computer system involving communications channels, operator interface devices, and/or data acquisition and control interfaces
$I_{OH}$	current, output high
$I_{OL}$	current, output low
IRQ	interrupt request signal
ISA	industry standard architecture

**L**

LabVIEW	Laboratory Virtual Instrument Engineering Workbench, a National Instruments graphical programming application
---------	---

**M**

m	meters
max	maximum
min	minimum
MITE	a custom ASIC designed by National Instruments that implements the PCI bus interface. The MITE supports bus mastering for high speed data transfers over the PCI bus.
motion encoders	transducers that generate pulses to indicate the physical motion of a device. The most common type of motion encoders are quadrature encoders. Two-pulse encoders (also referred to as up/down encoders) are another example.



## N

NI-DAQ	NI driver software for DAQ hardware
NI-TIO	a custom ASIC developed by National Instruments that provides counter and digital I/O functionality
noise	an undesirable electrical signal—noise comes from external sources such as the AC power line, motors, generators, transformers, fluorescent lights, soldering irons, CRT displays, computers, electrical storms, welders, radio transmitters, and internal sources such as semiconductors, resistors, and capacitors. Noise corrupts signals you are trying to send or receive.

## O

operating system	base-level software that controls a computer, runs programs, interacts with users, and communicates with installed hardware or peripheral devices
------------------	---

## P

PCI	Peripheral Component Interconnect—a high-performance expansion bus architecture originally developed by Intel to replace ISA and EISA. It is achieving widespread acceptance as a standard for PCs and work-stations; it offers a theoretical maximum transfer rate of 132 Mbytes/s.
PFI	programmable function input
port	(1) a communications connection on a computer or a remote controller (2) a digital port, consisting of lines of digital input and/or output
ppm	parts per million
prescaling	the division of frequency of an input signal that is to be used as SOURCE of a counter
programmed I/O	a data transfer method in which the CPU reads or writes data as prompted by software
PXI	modular instrumentation standard based on CompactPCI developed by National Instruments with enhancements for instrumentation

**Q**

**quadrature encoders** a motion encoder that has two channels: channels A and B. Pulses and phases of pulses on channels A and B carry information about degree and direction of movement. A third channel—channel Z—may also exist that provides a reference point for position.

**R**

**reflection** a high-speed signal transition behaves like a wave and is reflected like a wave at an inadequately terminated endpoint. This phenomenon is referred to as reflection.

**RG** reserved ground. Pins that are marked RG on the I/O connector are no-connects if you use the SH6868-D1 shielded cable, while they are ground pins if you use the R6868 unshielded ribbon cable.

**ribbon cable** a flat cable in which the conductors are side by side

**ringing** the oscillation of a signal about a high-voltage or low-voltage state immediately following a transition to that state

**RTSI Bus** real-time system integration bus—the National Instruments timing bus that connects DAQ boards directly, by means of connectors on top of the boards, for precise synchronization of functions

**S**

**s** seconds

**(HW) Save register** a register inside the NI-TIO ASIC that stores the result of a measurement

**source** in the counter context, source refers to the signal that causes the counter to increment or decrement. In the context of signals, source refers to the device that drives a signal.

**SOURCE** the signal that causes the counter to increment or decrement

**start trigger** a TTL level signal having two discrete levels—a high and a low level—that starts an operation

synchronous a property of an event that is synchronized to a reference clock

## T

TC terminal count—a strobe that occurs when a counter reaches zero from either direction

termination matching of impedances at the end of a signal path to minimize reflections.

timebase another term used for the SOURCE of a counter. Usually indicates an internal SOURCE provided by or derived from an onboard oscillator.

trigger any event that causes, starts, or stops some form of data capture

tri-state a third output state, other than high or low, in which the output is undriven

TTL transistor-transistor logic

two-pulse encoder a motion encoder that has two channels: channels A and B. Pulses on channel A indicate movement in one direction while pulses on channel B indicate movement in the opposite direction. This type of encoder is also referred to as up down encoder.

## U

unstrobed digital I/O a type of digital input or output in which software reads or writes the digital line or port states directly, without using any handshaking or hardware-controlled timing functions. Also called *immediate*, *nonhandshaking*, or *unlatched* digital I/O.

UP\_DOWN the signal that determines whether a counter increments or decrements

## V

V volts

VDC volts direct current

$V_{in}$  volts in

## **W**

wire                      data path between nodes

# Index

---

## A

arming of counters, simultaneous, 3-26  
AUX\_LINE selection for counter input  
(table), 4-10 to 4-11

## B

block diagram of PCI/PXI-6602 devices, C-1  
buffered counting and time measurements,  
3-10 to 3-14  
    buffered event counting, 3-11  
    buffered period measurement, 3-11 to 3-12  
    buffered periodic event counting, 3-15  
    buffered pulse-width measurement, 3-13  
    buffered semiperiod measurement, 3-12  
    buffered two-signal edge-separation  
    measurement, 3-13 to 3-14  
buffered frequency measurement, 3-16  
bulletin board support, D-1  
bus interface specifications, A-3

## C

CompactPCI products, 1-1 to 1-2  
    CompactPCI specification, 1-2  
    J2 pins used by PXI-6602 device (table), 1-2  
    using PXI with CompactPCI, 1-1 to 1-2  
configuration. *See* installation and configuration.  
continuous pulse-train generation, 3-9 to 3-10  
counter applications, 3-2 to 3-18  
    buffered counting and time measurements,  
    3-10 to 3-14  
        buffered event counting, 3-11  
        buffered period measurement,  
        3-11 to 3-12  
        buffered pulse-width  
        measurement, 3-13

        buffered semiperiod  
        measurement, 3-12  
        buffered two-signal edge-separation  
        measurement, 3-13 to 3-14  
buffered frequency measurement, 3-16  
buffered periodic event counting, 3-15  
event counting, 3-3 to 3-4  
    gated-event counting, 3-4  
    simple event counting, 3-4  
finite pulse-train generation, 3-17  
frequency division, 3-17  
frequency measurement, 3-16  
pulse generation, 3-7 to 3-9  
    pulse generation for ETS, 3-14 to 3-15  
    retriggerable single pulse generation,  
    3-8 to 3-9  
    simple pulse generation, 3-7 to 3-9  
    single pulse generation, 3-7 to 3-8  
    single-triggered pulse generation, 3-8  
pulse-train generation, 3-9 to 3-10  
    continuous pulse-train generation,  
    3-9 to 3-10  
    frequency shift keying (FSK), 3-10  
reciprocal frequency measurement,  
3-17 to 3-18, 3-23  
time measurement, 3-5 to 3-6  
    single pulse-width measurement,  
    3-5 to 3-6  
    single-period measurement, 3-5  
    two-signal edge-separation  
    measurement, 3-6  
types of counter applications (table),  
3-2 to 3-3  
counter input selections, 4-8 to 4-11  
counter output pins (table), 4-6 to 4-8  
counter timing specifications. *See* timing  
specifications.  
counters, in PCI/PXI-6602 devices, 3-1 to 3-2

crosstalk, 4-16  
customer communication, *xiii*, D-1 to D-2

## D

digital I/O, 3-25  
    specifications, A-2  
documentation  
    conventions used in manual, *xii*  
    National Instruments documentation,  
        *xii-xiii*  
    organization of manual, *xi*  
    related documentation, *xiii*

## E

electronic support services, D-1 to D-2  
e-mail support, D-2  
encoders  
    coders. *See* motion encoders.  
environment specifications, A-4  
equipment, optional, 1-6  
ETS pulse generation, 3-14 to 3-15  
event counting, 3-3 to 3-4  
    buffered event counting, 3-11  
    buffered periodic event counting, 3-15  
    gated-event counting, 3-4  
    simple event counting, 3-4

## F

fax and telephone support numbers, D-2  
Fax-on-Demand support, D-2  
field wiring and termination, 4-15  
filters, 3-20 to 3-22  
    filter clocks, 3-21 to 3-22  
    filter settings, 3-21  
    function of (figure), 3-21  
    properties of filter settings (table), 3-22  
finite pulse-train generation, 3-17

flexible period and frequency measurements,  
    3-22 to 3-25  
    errors with larger frequency (table), 3-22  
    simultaneous measurements using  
        counter 1 (figure), 3-24  
frequency division, 3-17  
frequency measurement, 3-16  
    buffered, 3-16  
    flexible period and frequency  
        measurements, 3-22 to 3-25  
    reciprocal, 3-17 to 3-18, 3-23  
FSK (frequency shift keying), 3-10  
FTP support, D-1

## G

GATE minimum pulse width, B-2 to B-3  
GATE selection for counter input (table), 4-10  
gated-event counting, 3-4

## H

hardware installation, 2-1 to 2-3

## I

inductive effects, 4-17 to 4-19  
    pin number of associated GND on 68-pin  
        connector block (table), 4-17 to 4-19  
    wiring to minimize (figure), 4-17  
installation and configuration, 2-1 to 2-3  
    hardware installation, 2-1 to 2-3  
    PCI and PXI device configuration, 2-3  
    software installation, 2-1  
    unpacking PCI/PXI-6602 devices, 1-3  
I/O characteristics, A-1 to A-2  
I/O connector, 4-1 to 4-14  
    counter input selections, 4-8 to 4-11  
    exceeding maximum input or output  
        ratings (caution), 4-1  
    output on counter pins, 4-6 to 4-8

**PFI lines**

- for counter applications (figure), 4-3
- for DIO applications (figure), 4-4
- functionality (figure), 4-2
- for motion encoder applications (figure), 4-5
- RTSI bus interface, 4-12 to 4-13
- signal characteristics, 4-12
- signals driven onto PFI lines (table), 4-6 to 4-8

**J**

J2 pins used by PXI-6602 device (table), 1-2

**L**

LabVIEW software, 1-4  
LabWindows/CVI software, 1-4

**M**

manual. *See* documentation.  
MITE PCI interface, 1-1  
motion encoders

- PFI lines for motion encoder applications (figure), 4-5
- quadrature encoders, 3-18 to 3-20
- two-pulse encoders, 3-20

**N**

National Instruments application software, 1-4  
NI-DAQ driver software, 1-4 to 1-5  
NI-TIO counter and digital I/O ASIC, 3-1 to 3-2  
noise, 4-15

**O**

optional equipment, 1-6  
output on counter pins, 4-6 to 4-8

**P**

pad synchronization, 3-26 to 3-28

- description, 3-26 to 3-27
- examples (figures), 3-27 to 3-28

**PCI/PXI-6602 devices**

- block diagram, C-1
- configuration, 2-3
- counter functionality, 3-1 to 3-2
- features, 1-1
- J2 pins used by PXI-6602 device (table), 1-2
- optional equipment, 1-6
- requirements for getting started, 1-2 to 1-3
- software programming choices, 1-3 to 1-5
  - National Instruments application software, 1-4
  - NI-DAQ driver software, 1-4 to 1-5
- unpacking, 1-3
- using PXI with CompactPCI, 1-1 to 1-2

**period measurement**

- buffered period measurement, 3-11 to 3-12
- buffered semiperiod measurement, 3-12
- counter source minimum period and minimum pulse width, B-1 to B-2
- flexible period and frequency measurements, 3-22 to 3-25
- single-period measurement, 3-5

**periodic event counting, buffered, 3-15**
**PFI lines**

- for counter applications (figure), 4-3
- for DIO applications (figure), 4-4
- functionality (figure), 4-2
- for motion encoder applications (figure), 4-5
- output on counter pins (table), 4-6 to 4-8
- pin number of associated GND on 68-pin connector block (table), 4-17 to 4-19
- possible selections for counter input (table), 4-9 to 4-11

- signals that can be driven onto (table), 4-6 to 4-8
- physical specifications, A-3
- position measurement, 3-18 to 3-20
  - quadrature encoders, 3-18 to 3-20
  - two-pulse encoders, 3-20
- power connections, 4-14
- power specifications, A-3
- prescaling, 3-26
- pull-up and pull-down connections, 4-13
- pulse generation, 3-7 to 3-9
  - pulse generation for ETS, 3-14 to 3-15
  - retriggerable single pulse generation, 3-8 to 3-9
  - simple pulse generation, 3-7 to 3-9
  - single pulse generation, 3-7 to 3-8
  - single-triggered pulse generation, 3-8
- pulse-train generation, 3-9 to 3-10
  - continuous pulse-train generation, 3-9 to 3-10
  - frequency shift keying (FSK), 3-10
- pulse-width measurement
  - buffered pulse-width measurement, 3-13
  - counter gate minimum pulse width, B-2
  - counter source minimum period and minimum pulse width, B-1 to B-2
  - single pulse-width measurement, 3-5 to 3-6
- PXI devices, using with CompactPCI products, 1-1 to 1-2
- PXI trigger bus (PXI-6602 only), A-3

## Q

- quadrature encoders, 3-18 to 3-20

## R

- reciprocal frequency measurement, 3-17 to 3-18, 3-23

- requirements for getting started, 1-2 to 1-3
- retriggerable single pulse generation, 3-8 to 3-9
- RTSI bus interface, 4-12 to 4-13
  - board and RTSI clocks, 4-13
  - RTSI triggers, 4-13
  - specifications, A-3

## S

- semiperiod measurement, buffered, 3-12
- signal characteristics, 4-12
- signal connections, 4-1 to 4-19
  - crosstalk, 4-16
  - field wiring and termination, 4-14
  - inductive effects, 4-17 to 4-19
    - pin number of associated GND on 68-pin connector block (table), 4-17 to 4-19
    - wiring to minimize (figure), 4-17
- I/O connector, 4-1 to 4-14
  - counter input selections, 4-8 to 4-11
  - exceeding maximum input or output ratings (caution), 4-1
  - output on counter pins, 4-6 to 4-8
  - PFI line functionality (figure), 4-2
  - PFI lines for counter applications (figure), 4-3
  - PFI lines for DIO applications (figure), 4-4
  - PFI lines for motion encoder applications (figure), 4-5
  - RTSI bus interface, 4-12 to 4-13
  - signal characteristics, 4-12
  - signals driven onto PFI lines (table), 4-6 to 4-8
  - noise, 4-15
  - power connections, 4-14
  - pull-up and pull-down connections, 4-13
  - transmission line effects, 4-14 to 4-15
- simultaneous arming of counters, 3-26



- single pulse generation, 3-7 to 3-8
  - retriggerable, 3-8 to 3-9
- single pulse-width measurement, 3-5 to 3-6
- single-period measurement, 3-5
- single-triggered pulse generation, 3-8
- software, 1-3 to 1-5
  - installation, 2-1
  - National Instruments application software, 1-4
  - NI-DAQ driver software, 1-4 to 1-5
- SOURCE selection for counter input (table), 4-9
- specifications, A-1 to A-4. *See also* timing specifications.
  - bus interface, A-3
  - digital I/O, A-2
  - environment, A-4
  - I/O characteristics, A-1 to A-2
  - physical, A-3
  - power, A-3
  - PXI trigger bus (PXI-6602 only), A-3
  - RTSI (PCI-6602 only), A-3
  - timing I/O, A-2
- synchronization at I/O pads, 3-26 to 3-28
- synchronous counting mode, 3-28 to 3-30
  - examples (figure), 3-29
  - when not to use, 3-29 to 3-30
  - when to use, 3-29

## T

- technical support, D-1 to D-2
- telephone and fax support numbers, D-2
- time measurement, 3-5 to 3-6. *See also* buffered counting and time measurements.
  - single pulse-width measurement, 3-5 to 3-6
  - single-period measurement, 3-5
  - two-signal edge-separation measurement, 3-6
- timing I/O specifications, A-2

- timing specifications, B-1 to B-3
  - counter gate minimum pulse width, B-2
  - counter source minimum period and minimum pulse width, B-1 to B-2
  - counter source to counter out delay, B-3
- transfer rates, 3-30 to 3-31
- transmission line effects, 4-15
- two-pulse encoders, 3-20
- two-signal edge-separation measurement, 3-6
  - buffered, 3-13 to 3-14

## U

- unpacking PCI/PXI-6602 devices, 1-3
- UP\_DOWN selection for counter input (table), 4-11